

- NOTES:
1. ALL WIRES TO BE xxxV, xx\*, xxx.
  2. OBSERVE DIRTY/CLEAN WIRING PRACTICES.
  3. Dx/Cx MARKERS INDICATE POTENTIAL ROUTING WIRING.
  4. ALL WIRES ARE #xx AWG, UNLESS OTHERWISE NOTED.
  5. ALL WIRES ARE xxx, UNLESS OTHERWISE NOTED.
  6. ALL GROUND WIRES ARE #xx AWG xxxxxxx, UNLESS OTHERWISE NOTED.

XXXXX_XXXX XXXXXX	SIMPLE SAFETY BI DIR MUTING W/LIGHT CURTAIN POWER DISTRIBUTION	DWG: XX DATE: 10-17-08 Dwg No: EXAMPLE Dwg Rev: XX
	SHEET: 1 OF XX	(Signature)

D

C

B

A

D

C

B

A

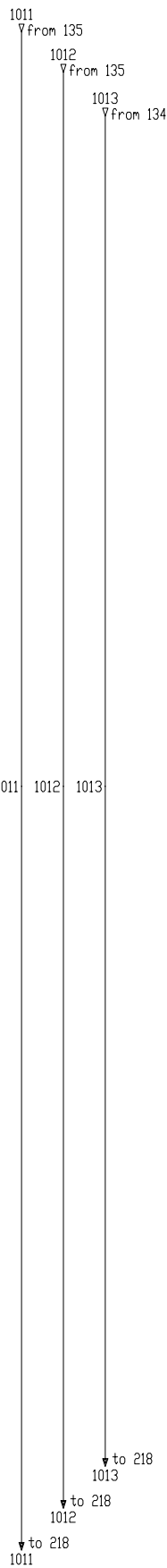

THIS SPACE INTENTIONALLY LEFT BLANK

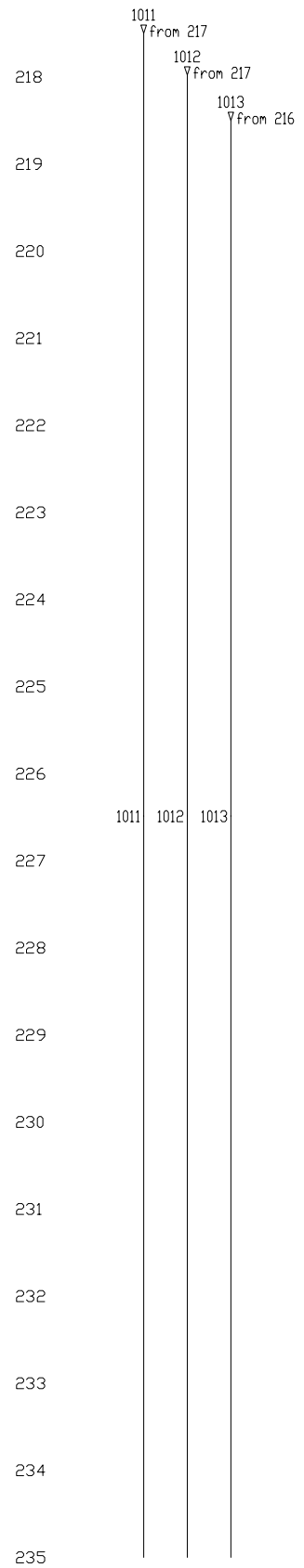

THIS SPACE INTENTIONALLY LEFT BLANK

XXXX XXXXXXXX XX XXX XXXXXXXXXXXX XX XXXXXXXXXXXX XXXXXXXXXXXX XX XXX XXXXXXXXXXXXXXXXXXXX XXXXXX XX XXXXXXXXXXXXXXXXXXXX XXXXXXX XXXXXXX XX XXXXXXXXXXXX	<b>XXXXXX_XXXX</b> <b>XXXXXX</b>	SIMPLE SAFETY BI DIR MUTING W/LIGHT CURTAIN POWER DISTRIBUTION	DWG XX DATE 10-17-08	DWG REV XX
		SHEET 2 OF XX	(C/A)	

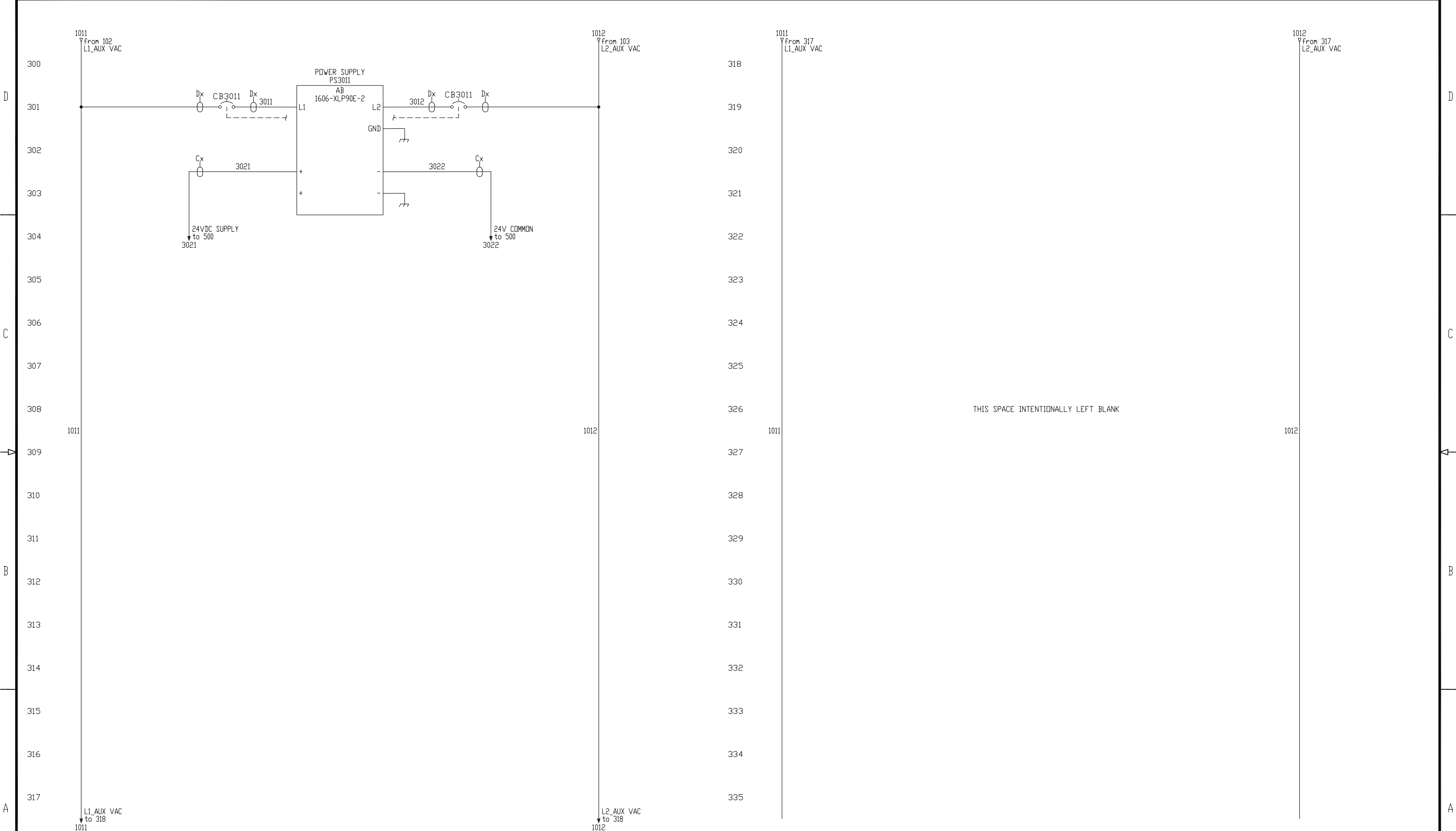

THIS SPACE INTENTIONALLY LEFT BLANK

- NOTES:
1. ALL WIRES TO BE xxxV, xx\*, xxx.
  2. OBSERVE DIRTY/CLEAN WIRING PRACTICES.
  3. Dx/Cx MARKERS INDICATE POTENTIAL ROUTING WIRING.
  4. ALL WIRES ARE #xx AWG, UNLESS OTHERWISE NOTED.
  5. ALL WIRES ARE xxx, UNLESS OTHERWISE NOTED.
  6. ALL GROUND WIRES ARE #xx AWG xxxxxx, UNLESS OTHERWISE NOTED.

XXXXX_XXXX XXXXXX	SIMPLE SAFETY BI DIR MUTING W/LIGHT CURTAIN 460VAC CONTROL	DWG XX DATE 10-17-08 Dwg REV EXAMPLE XX
	SHEET 3 OF XX	(C/A/C)

D

C

B

A

D

C

B

A

1013  
from 105  
VAC CONTROL

N  
from 106  
VAC NEUTRAL

1013  
from 417  
VAC CONTROL

N  
from 417  
VAC NEUTRAL

400  
401  
402  
403  
404  
405  
406  
407  
408  
409  
410  
411  
412  
413  
414  
415  
416  
417

418  
419  
420  
421  
422  
423  
424  
425  
426  
427  
428  
429  
430  
431  
432  
433  
434  
435

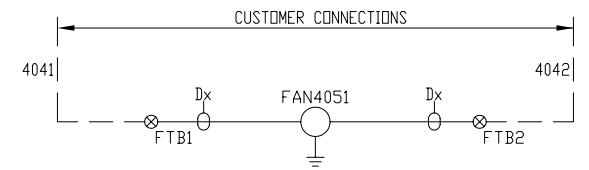

THIS SPACE INTENTIONALLY LEFT BLANK

1013

N

1013

N

VAC CONTROL  
to 418  
1013

VAC NEUTRAL  
to 418  
N

- NOTES:
1. ALL WIRES TO BE xxxV, xx\*, xxx.
  2. OBSERVE DIRTY/CLEAN WIRING PRACTICES.
  3. Dx/Cx MARKERS INDICATE POTENTIAL ROUTING WIRING.
  4. ALL WIRES ARE #xx AWG, UNLESS OTHERWISE NOTED.
  5. ALL WIRES ARE xxx, UNLESS OTHERWISE NOTED.
  6. ALL GROUND WIRES ARE #xx AWG xxxxxx, UNLESS OTHERWISE NOTED.

XXXX XXXXXXXX XX XXX XXXXXXXXXXXX XX XXXXXXXXXXXX XXXXXXXXXXXX XX XXX XXXXXXXXXXXX XXXXXXXXXXXX XXXXXX XX XXXXXXXXXXXX XXX XXX XXXXXX XXXXXXXX XX XXXXXXXXXXXX	<b>XXXXXX_XXXX</b> <b>XXXXXX</b>	SIMPLE SAFETY BI DIR MUTING W/LIGHT CURTAIN AUX VAC CONTROL	DWG XX DATE 10-17-08	DWG REV XX
		SHEET 4 OF XX	(C) (A)	

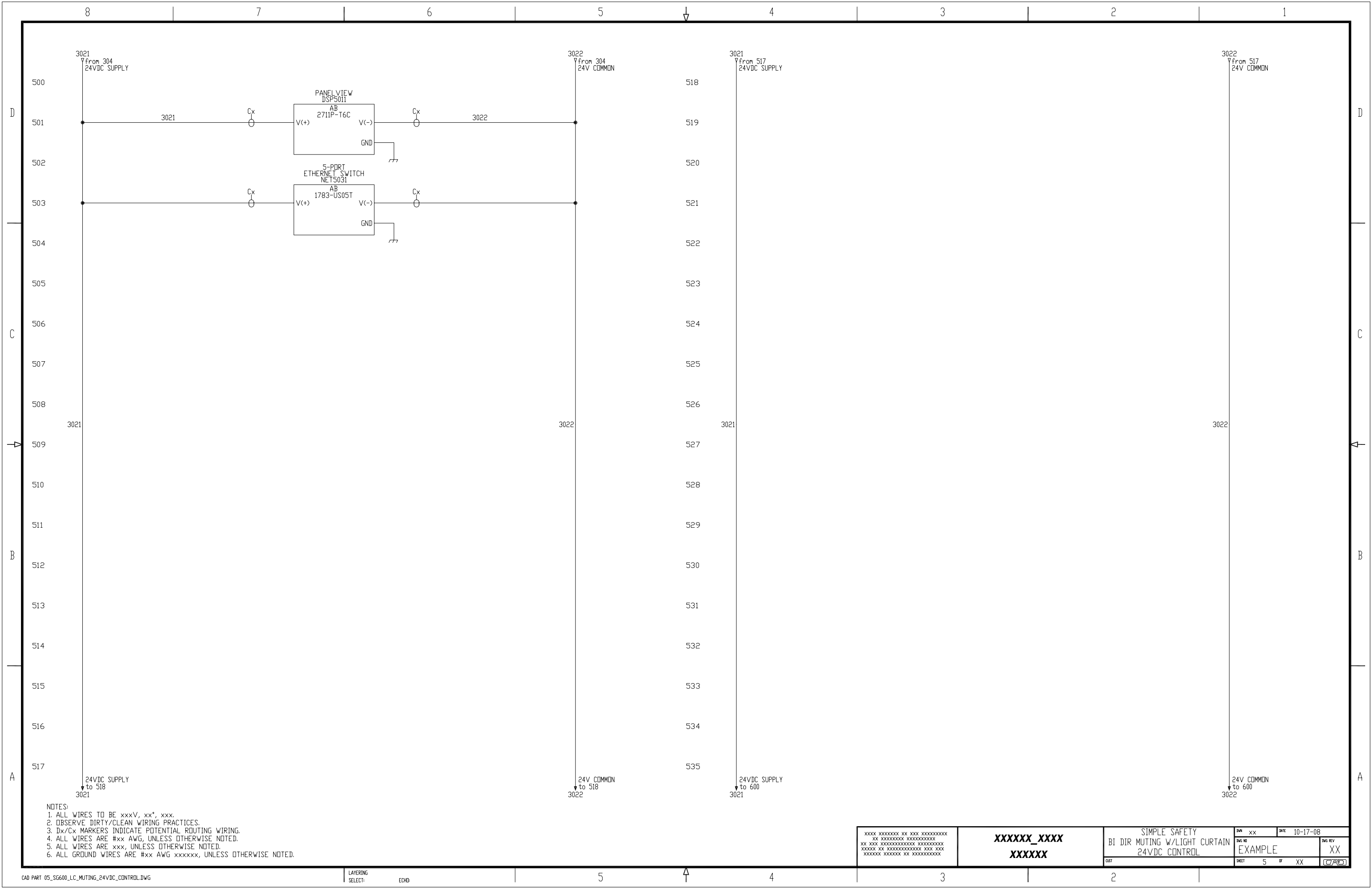

- NOTES:
1. ALL WIRES TO BE xxxV, xx\*, xxx.
  2. OBSERVE DIRTY/CLEAN WIRING PRACTICES.
  3. Dx/Cx MARKERS INDICATE POTENTIAL ROUTING WIRING.
  4. ALL WIRES ARE #xx AWG, UNLESS OTHERWISE NOTED.
  5. ALL WIRES ARE xxx, UNLESS OTHERWISE NOTED.
  6. ALL GROUND WIRES ARE #xx AWG xxxxxx, UNLESS OTHERWISE NOTED.

XXXXX_XXXX XXXXXX	SIMPLE SAFETY BI DIR MUTING W/LIGHT CURTAIN 24VDC CONTROL	DWG NO: XX DATE: 10-17-08	DWG REV: XX
	SHEET: 5 OF XX	(Signature)	

D

C

B

A

D

C

B

A

3021  
from 535  
24VDC SUPPLY

3022  
from 535  
24V COMMON

3021  
from 617  
24VDC SUPPLY

3022  
from 617  
24V COMMON

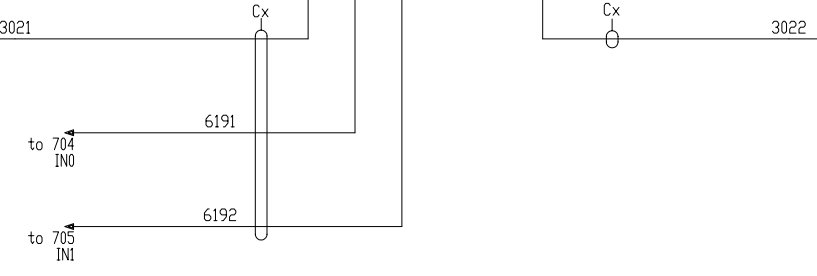
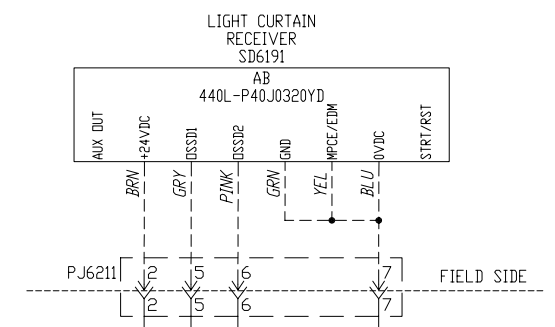

THIS SPACE INTENTIONALLY LEFT BLANK

600  
601  
602  
603  
604  
605  
606  
607  
608  
609  
610  
611  
612  
613  
614  
615  
616  
617

618  
619  
620  
621  
622  
623  
624  
625  
626  
627  
628  
629  
630  
631  
632  
633  
634  
635

24VDC SUPPLY  
to 618  
3021

24V COMMON  
to 618  
3022

24VDC SUPPLY  
to 700  
3021

24V COMMON  
to 700  
3022

- NOTES:
1. ALL WIRES TO BE xxxV, xx\*, xxx.
  2. OBSERVE DIRTY/CLEAN WIRING PRACTICES.
  3. Dx/Cx MARKERS INDICATE POTENTIAL ROUTING WIRING.
  4. ALL WIRES ARE #xx AWG, UNLESS OTHERWISE NOTED.
  5. ALL WIRES ARE xxx, UNLESS OTHERWISE NOTED.
  6. ALL GROUND WIRES ARE #xx AWG xxxxxx, UNLESS OTHERWISE NOTED.

XXXXX_XXXX XXXXXX	SIMPLE SAFETY BI DIR MUTING W/LIGHT CURTAIN LIGHT CURTAIN	DWG NO EXAMPLE	DWG REV XX
	DWT 6 OF XX	DATE 10-17-08	[Signature]

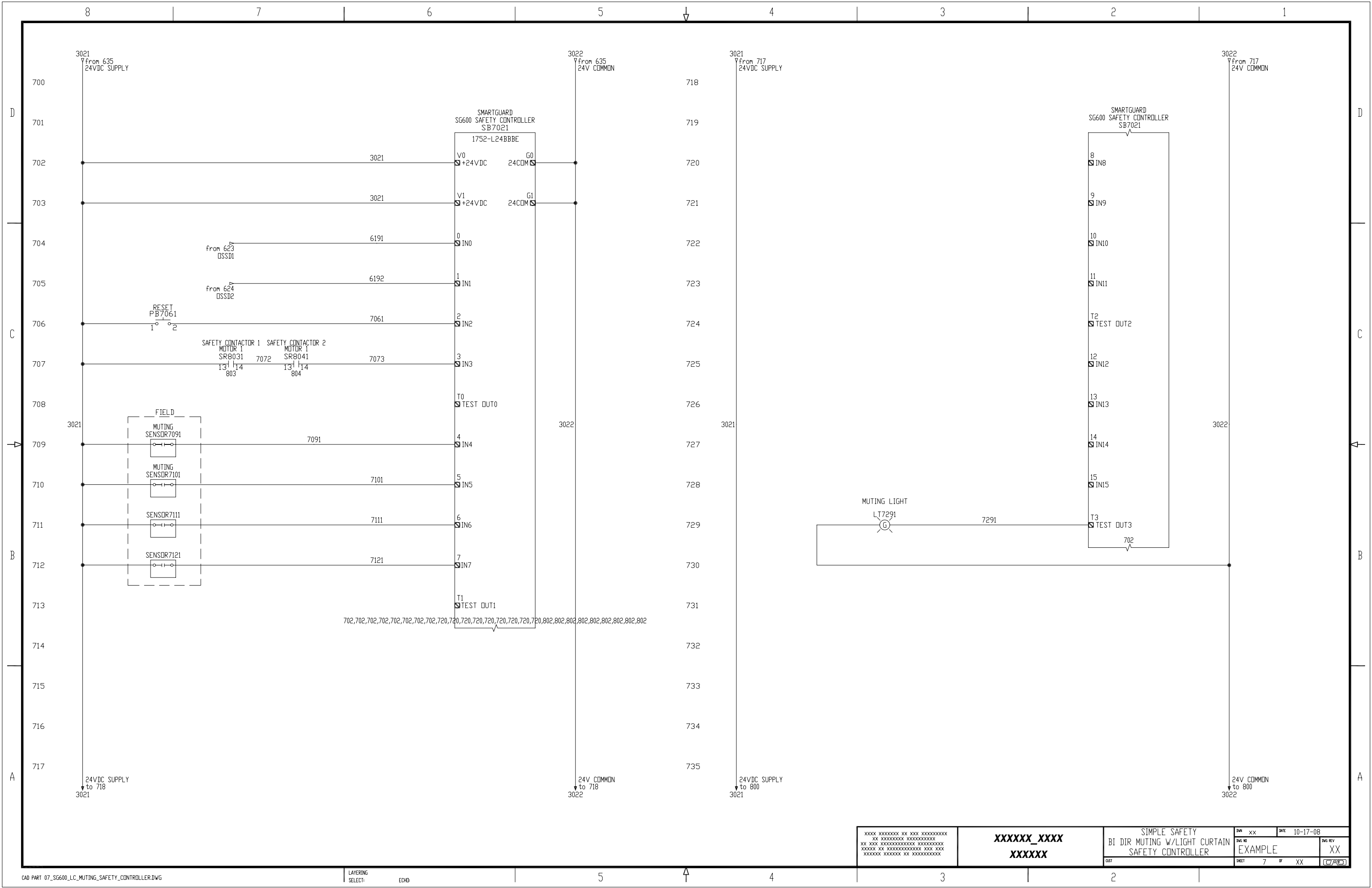

XXXX XXXXXXXX XX XXX XXXXXXXXXXXX XX XXXXXXXXXXXX XXXXXXXXXXXX XX XXXXXXXXXXXX XXXXXXXXXXXX XXXXXX XX XXXXXXXXXXXX XXX XXX XXXXXXXX XXXXXX XX XXXXXXXXXXXX	XXXXXX_XXXX XXXXXX	SIMPLE SAFETY BI DIR MUTING W/LIGHT CURTAIN SAFETY CONTROLLER	DWG XX DATE 10-17-08 DWG REV EXAMPLE XX	DWG REV XX
			SHEET 7 OF XX	

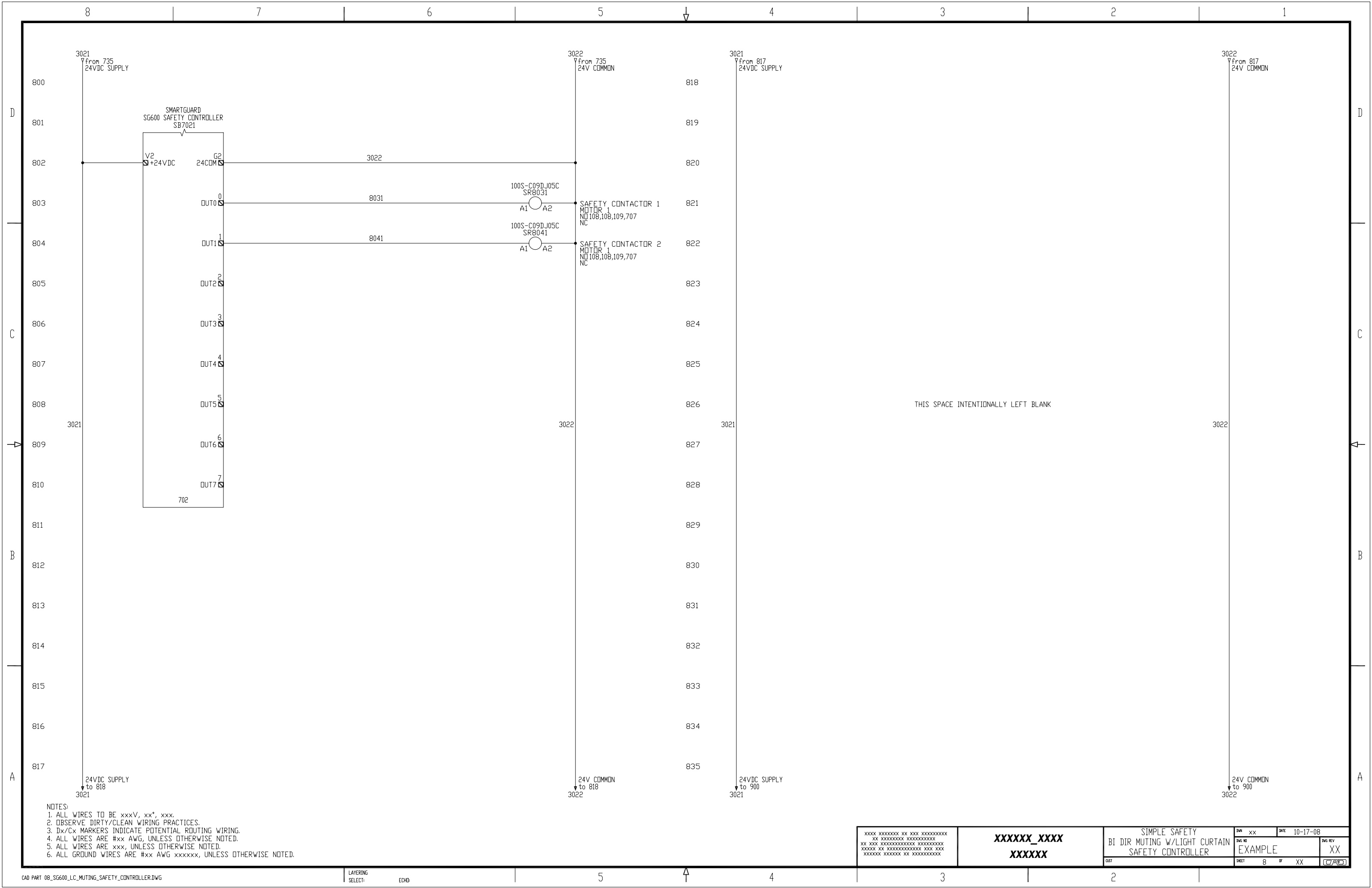

- NOTES:
1. ALL WIRES TO BE xxxV, xx\*, xxx.
  2. OBSERVE DIRTY/CLEAN WIRING PRACTICES.
  3. Dx/Cx MARKERS INDICATE POTENTIAL ROUTING WIRING.
  4. ALL WIRES ARE #xx AWG, UNLESS OTHERWISE NOTED.
  5. ALL WIRES ARE xxx, UNLESS OTHERWISE NOTED.
  6. ALL GROUND WIRES ARE #xx AWG xxxxxx, UNLESS OTHERWISE NOTED.

XXXX XXXXXXXX XX XXX XXXXXXXXXXXX XX XXXXXXXXXXXX XXXXXXXXXXXX XX XXX XXXXXXXXXXXX XXXXXXXXXXXX XXXXXX XX XXXXXXXXXXXX XXX XXX XXXXXXXX XXXXXXXX XX XXXXXXXXXXXX	<b>XXXXXX_XXXX</b> <b>XXXXXX</b>	SIMPLE SAFETY BI DIR MUTING W/LIGHT CURTAIN SAFETY CONTROLLER	DWG NO <b>EXAMPLE</b>	DATE 10-17-08	DWG REV <b>XX</b>
			SHEET 8	OF XX	

8

7

6

5

4

3

2

1

3021  
from 835  
24VDC SUPPLY

3022  
from 835  
24V COMMON

3021  
from 917  
24VDC SUPPLY

3022  
from 917  
24V COMMON

900  
901  
902  
903  
904  
905  
906  
907  
908  
909  
910  
911  
912  
913  
914  
915  
916  
917

918  
919  
920  
921  
922  
923  
924  
925  
926  
927  
928  
929  
930  
931  
932  
933  
934  
935

24VDC SUPPLY  
to 918  
3021

24V COMMON  
to 918  
3022

24VDC SUPPLY  
to 1000  
3021

24V COMMON  
to 1000  
3022

THIS SPACE INTENTIONALLY LEFT BLANK

THIS SPACE INTENTIONALLY LEFT BLANK

- NOTES:
1. ALL WIRES TO BE xxxV, xx\*, xxx.
  2. OBSERVE DIRTY/CLEAN WIRING PRACTICES.
  3. Dx/Cx MARKERS INDICATE POTENTIAL ROUTING WIRING.
  4. ALL WIRES ARE #xx AWG, UNLESS OTHERWISE NOTED.
  5. ALL WIRES ARE xxx, UNLESS OTHERWISE NOTED.
  6. ALL GROUND WIRES ARE #xx AWG xxxxxx, UNLESS OTHERWISE NOTED.

XXXXX_XXXX XXXXXX	SIMPLE SAFETY BI DIR MUTING W/LIGHT CURTAIN DRIVE SPARE	DWG NO EXAMPLE	DWG REV XX
	DWG XX DATE 10-17-08	SHEET 9 OF XX	(C/A/C)

5

4

3

2

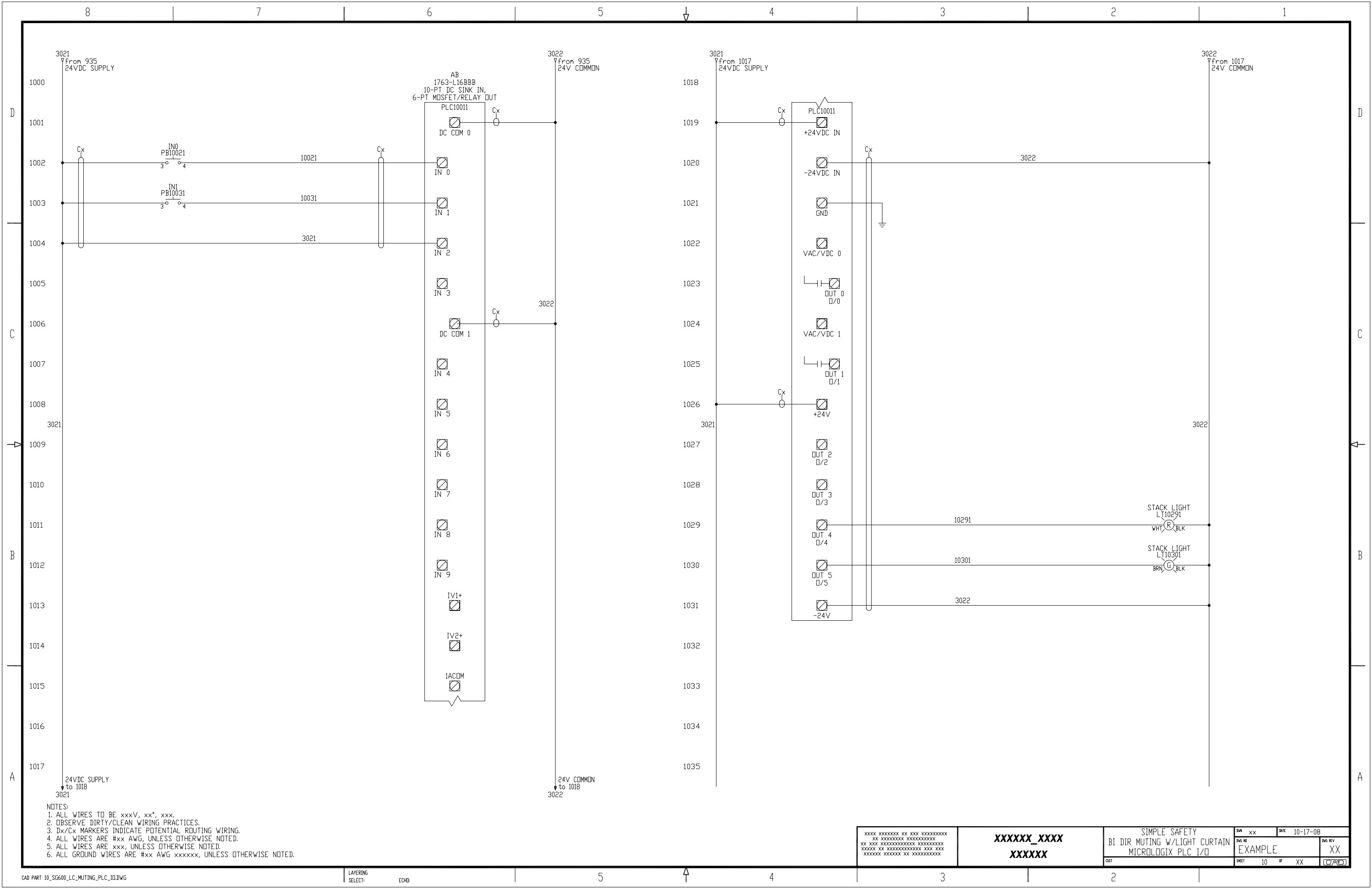

- NOTES:
1. ALL WIRES TO BE xxxV, xx\*, xxx.
  2. OBSERVE DIRTY/CLEAN WIRING PRACTICES.
  3. Dx/Cx MARKERS INDICATE POTENTIAL ROUTING WIRING.
  4. ALL WIRES ARE #xx AWG, UNLESS OTHERWISE NOTED.
  5. ALL WIRES ARE xxx, UNLESS OTHERWISE NOTED.
  6. ALL GROUND WIRES ARE #xx AWG xxxxxx, UNLESS OTHERWISE NOTED.

XXXX XXXXXXXX XX XXX XXXXXXXXXXXX XX XXXXXXXXXXXX XXXXXXXXXXXX XX XXX XXXXXXXXXXXX XXXXXXXXXXXX XXXXXX XX XXXXXXXXXXXX XXX XXX XXXXXXX XXXXXXX XX XXXXXXXXXXXX	<b>XXXXXX_XXXX</b> <b>XXXXXX</b>	SIMPLE SAFETY BI DIR MUTING W/LIGHT CURTAIN MICROLOGIX PLC I/O	DWG: XX    DATE: 10-17-08 DWG NO: EXAMPLE    DWG REV: XX SHEET: 10 OF XX
--	-------------------------------------	--	--

8

7

6

5

4

3

2

1

D

D

C

C

B

B

A

A

1100  
1101  
1102  
1103  
1104  
1105  
1106  
1107  
1108  
1109  
1110  
1111  
1112  
1113  
1114  
1115  
1116  
1117

1118  
1119  
1120  
1121  
1122  
1123  
1124  
1125  
1126  
1127  
1128  
1129  
1130  
1131  
1132  
1133  
1134  
1135

THIS SPACE INTENTIONALLY LEFT BLANK

THIS SPACE INTENTIONALLY LEFT BLANK

XXXX XXXXXXXX XX XXX XXXXXXXXXXXX  
XX XXXXXXXXXXXX XXXXXXXXXXXX  
XX XXX XXXXXXXXXXXX XXXXXXXXXXXX  
XXXXXXXX XX XXXXXXXXXXXX XXX XXX  
XXXXXXXX XXXXXXXX XX XXXXXXXXXXXX

XXXXXX\_XXXX  
XXXXXX

SIMPLE SAFETY  
BI DIR MUTING W/LIGHT CURTAIN  
PLC I/O SPARE

DWG NO  
EXAMPLE

DWG REV  
XX

DWG DATE 10-17-08  
SHEET 11 OF XX

CRD

5

4

3

2

HMI PANELVIEW 600C  
2711C-T6C

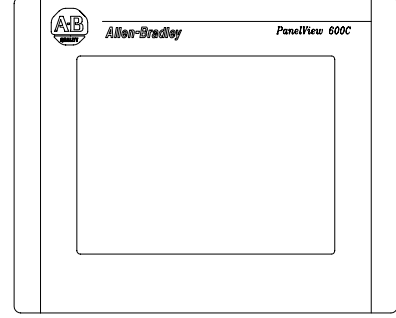

5PORT ETHERNET  
SWITCH  
1783-US05T

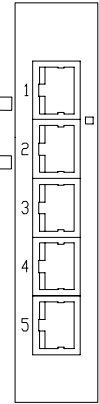

SMARTGUARD 600 w/ETHERNET  
1752-L24BBBE

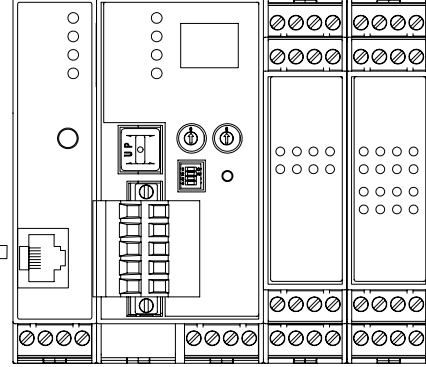

MICROLOGIX 1100  
1763-L16BBB

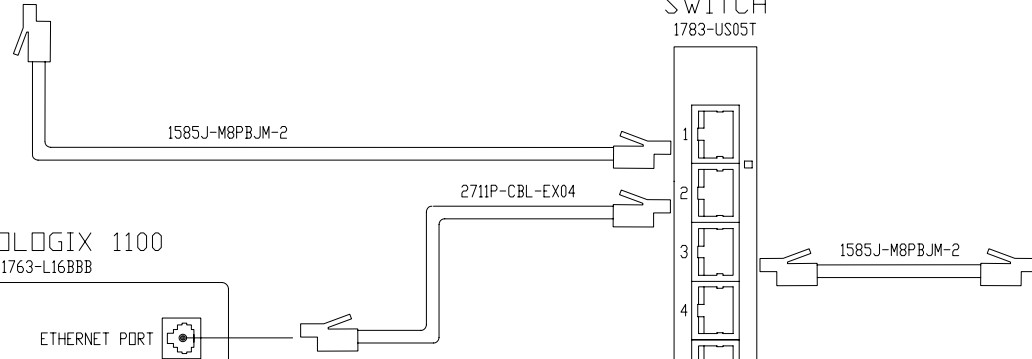
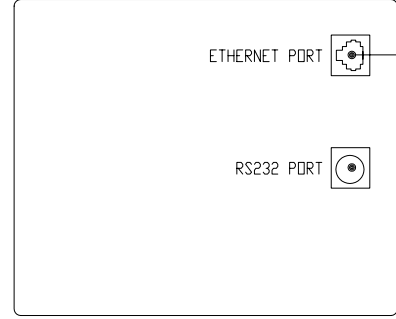

XXXX XXXXXXXX XX XXX XXXXXXXXXXXX XX XXXXXXXXXXXX XXXXXXXXXXXXXXXX XX XXX XXXXXXXXXXXXXXXX XXXXXXXXXXXX XXXXXXXX XX XXXXXXXXXXXXXXXX XXX XXX XXXXXXXX XXXXXXXX XX XXXXXXXXXXXXXXXX	XXXXXX_XXXX XXXXXX	SIMPLE SAFETY BI DIR MUTING W/LIGHT CURTAIN COMMUNICATION DIAGRAM	DWG XX DATE 10-17-08 EXAMPLE	DWG REV XX
			SHEET 12 OF XX	(PAC)

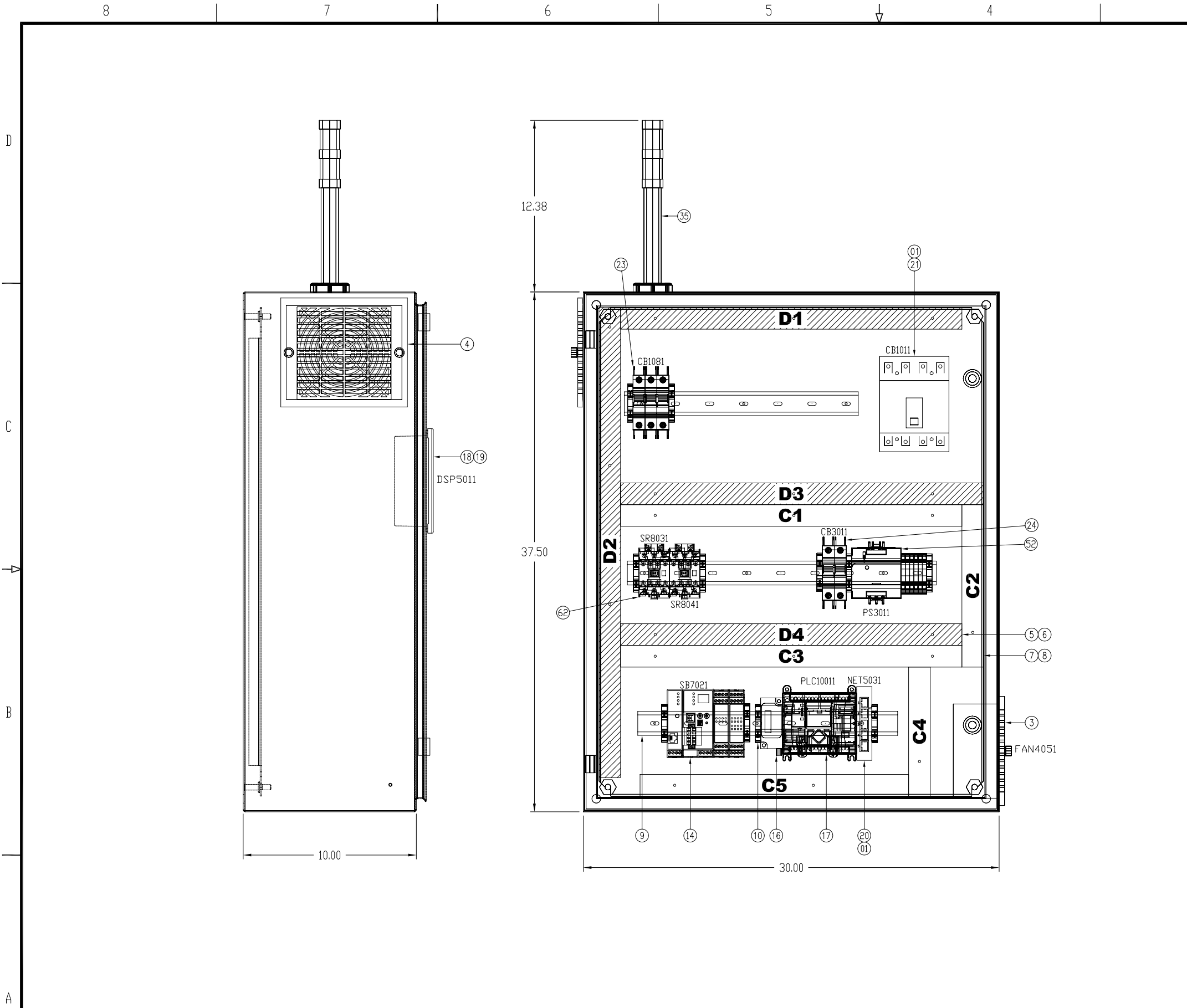

ITEM	QTY	DESCRIPTION	MFG	CATALOG
1	1	NEMA1 ENCLOSURE 30"x24"x10"	HOFFMAN	CSD302410
2	1	PANEL FOR ENCLOSURE 21"x22.5"	HOFFMAN	CP3024
3	1	FAN KIT 115VAC WITH FILTER	HOFFMAN	TFP41
4	1	EXHAUST GRILL WITH FILTER	HOFFMAN	TEP4
5	-	PANDUIT WIRE DUCT, 1"x4" GRAY	PANDUIT	F1X4LG6
6	-	PANDUIT WIRE DUCT COVER, 1" GRAY	PANDUIT	C1LG6
7	-	PANDUIT WIRE DUCT, 1" X4" WHITE	PANDUIT	F1X4WH6
8	-	PANDUIT WIRE DUCT COVER, 1" WHITE	PANDUIT	C1WH6
9	-	35MM DIN RAIL	AB	199-DR1
10	9	END ANCHOR USED W/STANDARD 35MM DIN	AB	1492-EAJ35
11	-	-	-	-
12	-	-	-	-
13	-	-	-	-
14	1	SMARTGUARD 600 SMALL SAFETY CONTROLLER w/ETHERNET	AB	1752-L24BBB
CONTROL AND VISUALIZATION EQUIPMENT				
15	1	1763 MICROLOGIX 1100 SYSTEM GROUP SELECTION		
16	1	CABLE: MICROLOGIX 1100 CHANNEL 0 TO RS-485	AB	1763-NC01
17	1	MICROLOGIX 1100, 24V DC POWER	AB	1763-L16BBB
18	1	6" COLOR (TRANSMISSIVE CSTN) TOUCHSCREEN	AB	2711C-T6C
19	2	1585 ETHERNET CABLE, TEAL RISER PVC, 2 METER	AB	1585J-MBPBJM-2
20	1	STRATIX 2000 SWITCH, UNMANAGED, 5 COPPER PORTS	AB	1783-US05T
POWER CIRCUIT COMPONENTS				
380 VAC - 480 VAC, 4 POLE C.B. DISCONNECT OPTION				
21	1	IEC MOLDED CASE C.B., 160A, H-FRAME, RATED 32A	AB	140UE-H2E4-C32
22	1	ROTARY, VARIABLE-DEPTH OPERATING MECHANISM	AB	140U-H-RVM12R
23	1	UL489/CSA 22.2 NO 5.1 CIRCUIT BREAKER, 3 POLE, 7 AMP	AB	1489-A3C070
24	1	UL489/CSA 22.2 NO 5.1 CIRCUIT BREAKER, 2 POLE 10 AMP	AB	1489-A2D100
380/400 VAC, 3 POLE FUSED DISCONNECT OPTION				
25	1	194R DISCONNECT, OPEN STYLE, DIN, 32A, 3 POLE	AB	194R-D32-1753
26	1	OPERATING HANDLE, WITH DEFEATER, RED/YELLOW	AB	194R-HS4E
27	1	OPERATING SHAFT, STANDARD LENGTH, 263MM (10.3 IN.)	AB	194R-R1
28	1	UL489/CSA 22.2 NO 5.1 CIRCUIT BREAKER, 3 POLE, 7 AMP	AB	1489-A3C070
29	1	UL489/CSA 22.2 NO 5.1 CIRCUIT BREAKER, 2 POLE, 10 AMP	AB	1489-A2D100
480 VAC, 3 POLE FUSED DISCONNECT OPTION				
30	1	194R DISCONNECT, OPEN STYLE, 30A, 3 POLE	AB	194R-C30-1753
31	1	OPERATING HANDLE, WITH DEFEATER, RED/YELLOW	AB	194R-HS4E
32	1	OPERATING SHAFT, STANDARD LENGTH, 263MM (10.3 IN.)	AB	194R-R1
33	1	UL489/CSA 22.2 NO 5.1 CIRCUIT BREAKER, 3 POLE, 7 AMP	AB	1489-A3C070
34	1	UL489/CSA 22.2 NO 5.1 CIRCUIT BREAKER, 2 POLE, 10 AMP	AB	1489-A2D100
SENSORS/STACKLIGHTS				
35	1	COMPACT TOWER LIGHT, 30 MM, GRN, RED LED	AB	855D-P25SC20G24Y3Y4
36	1	PHOTOSWITCH PHOTOELECTRIC SENSOR, RIGHTSIGHT	AB	42EF-P2MPB-F4
37	1	60-2695 BRACKET, (USE W/ 60-2439, 60-2649)	AB	60-2695
38	1	PATCHCORD: DC MICRO (M12), FEMALE, STRAIGHT, 4-PIN	AB	889D-F4ACDM-2
39	1	RECEPTACLE, DC MICRO (M12), FEMALE, STRAIGHT, 4-PIN	AB	888D-F4AC1-1
PUSHBUTTONS				
40	1	800F 3 POSITION S.S. - PLASTIC, MAINTAINED, BLACK	AB	800FP-SM32
41	1	800F LEGEND PLATE, ENGLISH: AUTO - OFF - HAND	AB	800F-11WE104
42	2	22.5MM PB NO LATCH, SCREW CONTACT BLOCK, 1 N.O.	AB	800F-X10
43	1	PLASTIC LATCH	AB	800F-ALP
44	1	800F PUSH BUTTON - PLASTIC, FLUSH, GREEN, 1	AB	800FP-F306
45	1	PLASTIC LATCH	AB	800F-ALP
46	1	22.5MM PB NO LATCH, SCREW CONTACT BLOCK, 1 N.O.	AB	800F-X10
47	1	800F PUSH BUTTON - PLASTIC, EXTENDED, RED, 0	AB	800FP-E405
48	1	PLASTIC LATCH	AB	800F-ALP
49	1	22.5MM PB NO LATCH, SCREW CONTACT BLOCK, 1 N.O.	AB	800F-X10
PROGRAMMING SOFTWARE				
50	1	RSNETWORK FOR DEVICENET	AB	9357-DNETL3
51	1	RSLOGIX MICRO STARTER (ENGLISH) CD-ROM	AB	9324-RLM0100ENE

NOTES:  
 1. WIREWAYS MARKED Cx/Dx INDICATE CLEAN/DIRTY SIGNAL/POWER  
 2. FOR FURTHER INFORMATION ON SYSTEM DESIGN FOR CONTROL OF ELECTRICAL NOISE SEE ROCKWELL PUBLICATION #GMC RM001-EN-P

XXXX XXXXXX XX XXX XXXXXXXX XX XXX XXXXXXXXXXXX XXXXXXXX XXXXXX XX XXXXXXXXXXXX XXX XXX XXXXXX XXXXXXX XX XXXXXXXXXX	XXXXXX_XXXX XXXXXX	SIMPLE SAFETY BI DIR MUTING W/LIGHT CURTAIN PANEL LAYOUT	DWG NO EXAMPLE	DATE 10-17-08	DWG REV XX
			SHEET 13	OF XX	DATE 10-17-08

8

7

6

5

4

3

2

1

ADDITIONAL PARTS LIST

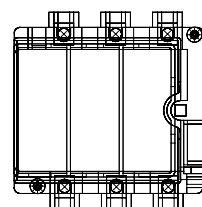

30 30A FUSED DISCONNECT

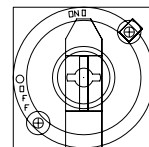

22 ROTARY VARIABLE DEPTH MECHANISM

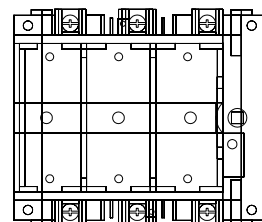

25 60A FUSED DISCONNECT

CONTROL CIRCUIT COMPONENTS				
52	1	1606-XLP90E-2: COMPACT PWS, 24-28V, 90 W, 480VAC	AB	1606-XLP90E-2
E-STOP PUSHBUTTON				
53	1	800F NON-ILLUMINATED MUSHROOM, TWIST TO RELEASE	AB	800FP-MT44
54	1	PLASTIC LATCH	AB	800F-ALP
55	1	22.5MM PB NO LATCH, SCREW CONTACT BLOCK, 2 N.C.	AB	800F-X02D
SAFETY EQUIPMENT				
56	1	GUARDSHIELD SAFETY LIGHT CURTAIN	AB	440L-P4J0320YD
57	1	CORDSET: DC MICRO (M12), FEMALE, STRAIGHT, 4-PIN	AB	889D-F4AC-5
58	1	CORDSET: DC MICRO (M12), FEMALE, STRAIGHT, 8-PIN	AB	889D-F8AB-5
59	4	PHOTOSWITCH PHOTOELECTRIC SENSOR	AB	42GRU-9200-QD
60	4	CORDSET: DC MICRO (M12), FEMALE, STRAIGHT, 4-PIN	AB	889D-F4BC-5
61	4	60-2695 BRACKET, IMPACT RESISTANT	AB	60-2695
62	2	MCS 100S-C SAFETY CONTACTOR, 9A, 24V DC	AB	100S-C09DJ05C
63	1	1606-XL120D: STANDARD POWER SUPPLY, 24V DC, 120 W	AB	1606-XL120D
64	1	MUTING INDICATOR LED LAMP, INCL 10M CABLE	AB	440L-AMUTLP10M

XXXX XXXXXXXX XX XXX XXXXXXXXXXXX XX XXXXXXXXXXXX XXXXXXXXXXXX XX XXX XXXXXXXXXXXX XXXXXXXXXXXX XXXXXXXX XX XXXXXXXXXXXX XXX XXX XXXXXXXX XXXXXXXX XX XXXXXXXXXXXX	<b>XXXXXX_XXXX</b> <b>XXXXXX</b>	SIMPLE SAFETY BI DIR MUTING W/LIGHT CURTAIN ADDITIONAL PARTS	DWG NO <b>EXAMPLE</b>	DATE 11-07-08	DWG REV <b>XX</b>
			SHEET 14	OF XX	

5

4

3

2

8 7 6 5 4 3 2 1

D

C

B

A

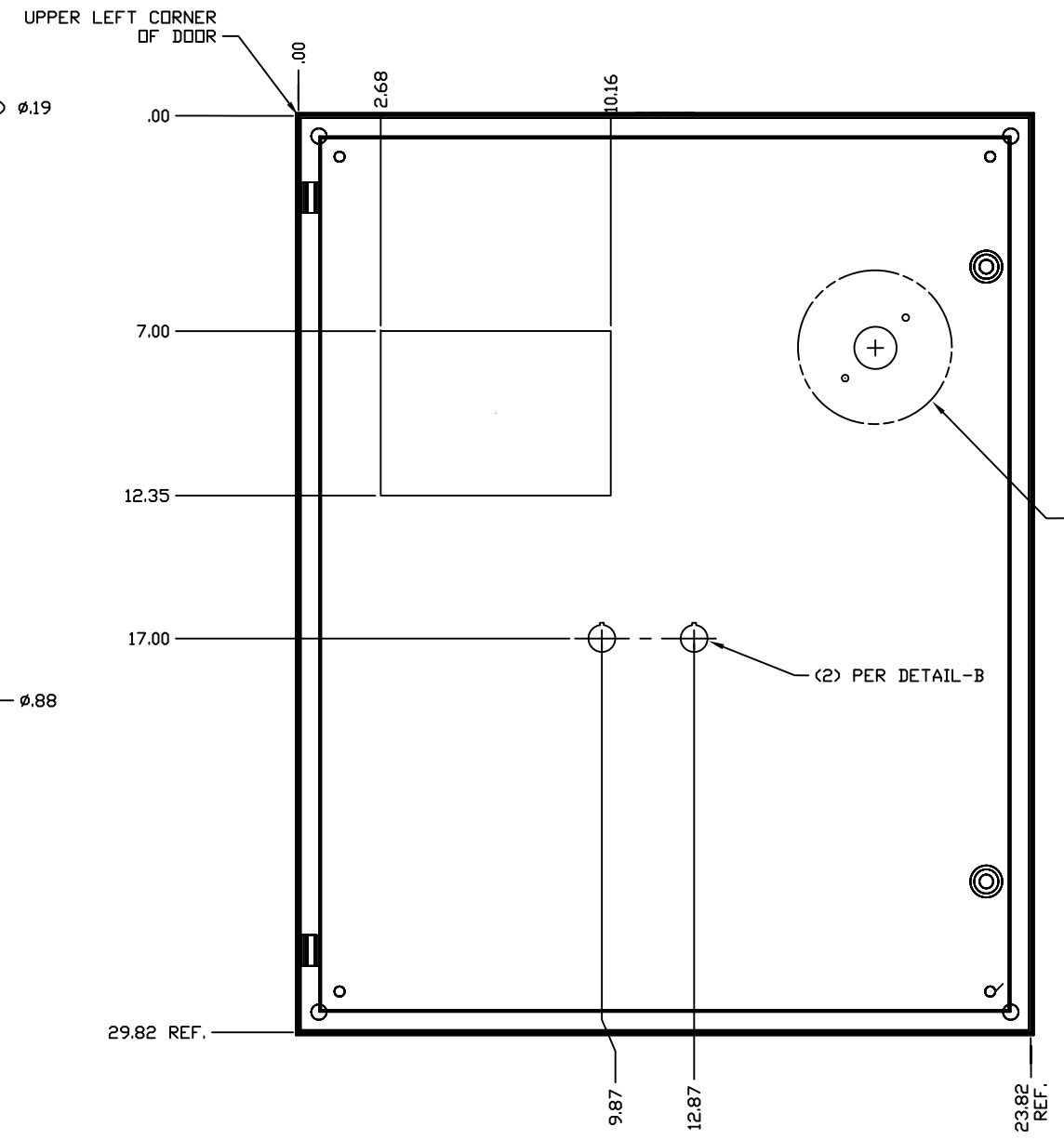
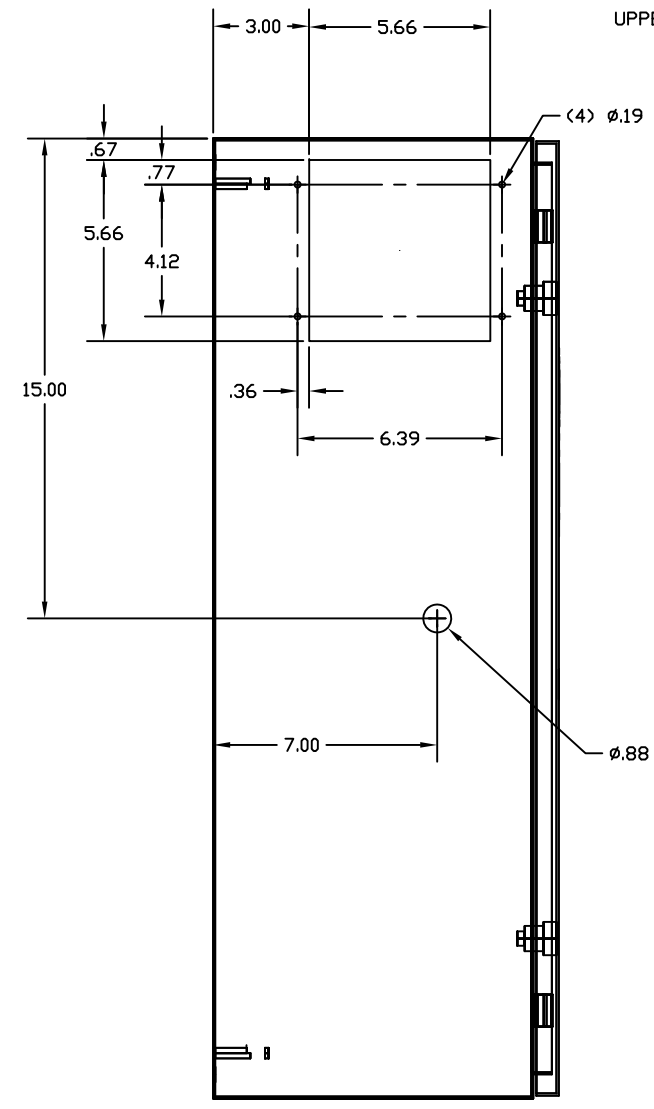
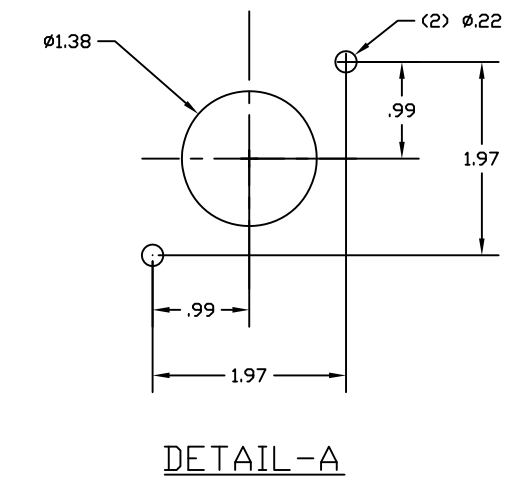
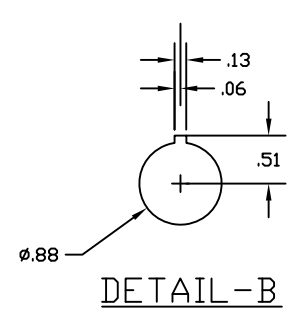
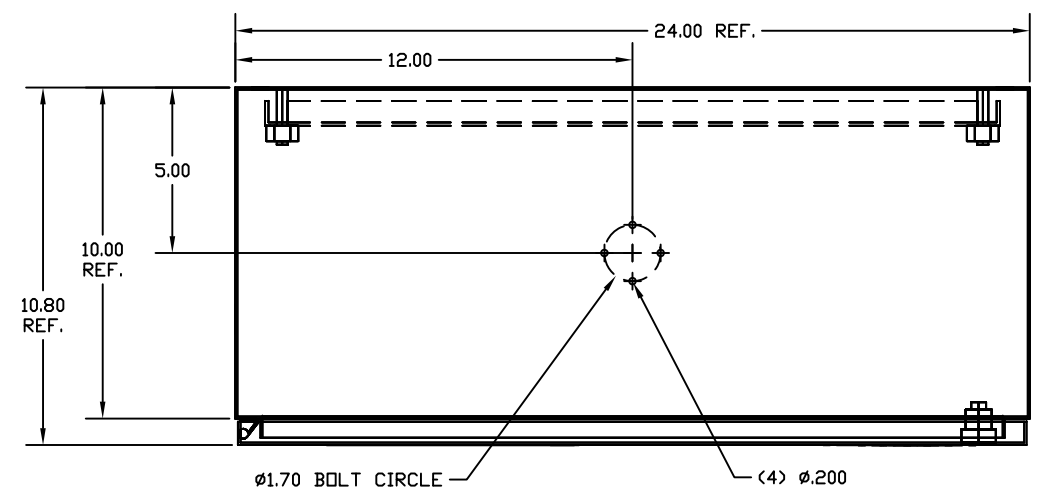

PER DETAIL-A,  
(SEE SHEET 2 FOR ALL  
OPERATOR OPTION  
LOCATIONS)

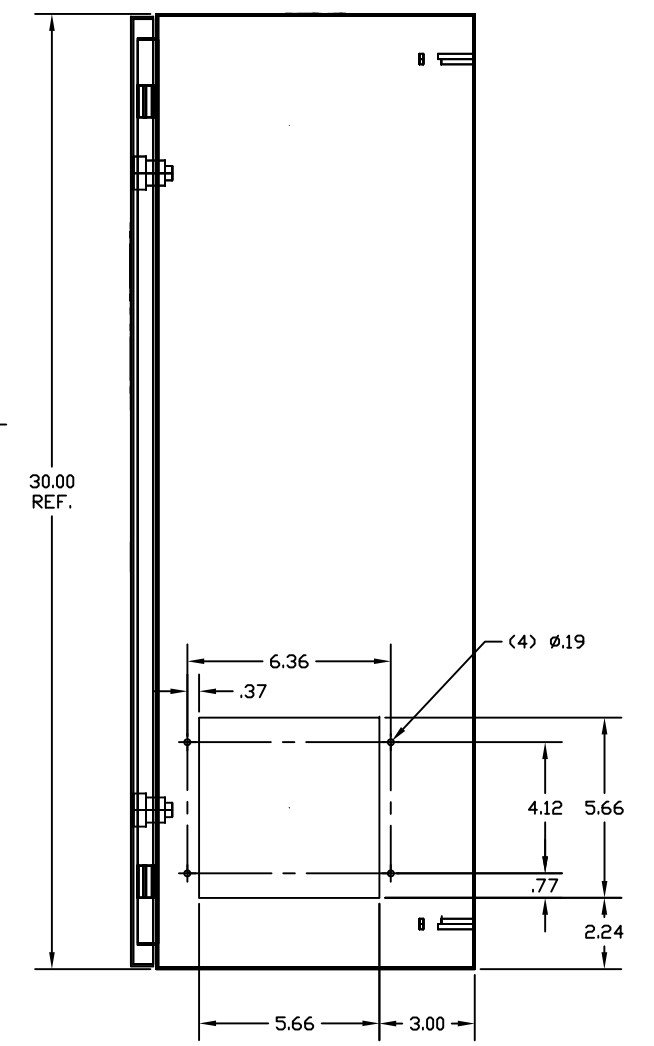

**DOOR MODIFICATION**

-01	1	HOFFMAN PART CSD302410	ANSI 61 GRAY
PART NO.	CHG. CHAR.	MATERIAL	SURFACE TREATMENT

LAYERING SELECT: ECHD

XXXX XXXXXXXX XX XXX XXXXXXXXXX XX XXX XXXXXXXXXX XXXXXXXXXX XXXXXX XX XXXXXXXXXX XXX XXX XXXXXX XXXXXXXX XX XXXXXXXXXX	XXXXXX_XXXX XXXXXX	SIMPLE SAFETY BI DIR MUTING W/LIGHT CURTAIN ENCLOSURE DOOR LAYOUT	DWG XX DATE 10-17-08 REV XX EXAMPLE SHEET 15 OF XX
--	-----------------------	---	--

8 7 6 5 4 3 2 1