

- NOTES:
1. ALL WIRES TO BE xxxV, xx*, xxx.
 2. OBSERVE DIRTY/CLEAN WIRING PRACTICES.
 3. Dx/Cx MARKERS INDICATE POTENTIAL ROUTING WIRING.
 4. ALL WIRES ARE #xx AWG, UNLESS OTHERWISE NOTED.
 5. ALL WIRES ARE xxx, UNLESS OTHERWISE NOTED.
 6. ALL GROUND WIRES ARE #xx AWG xxxxxx, UNLESS OTHERWISE NOTED.

XXXXX_XXXX XXXXX	SIMPLE SAFETY SINGLE SAFETY GATE POWER DISTRIBUTION	DWG: XX DATE: 10-17-08	DWG REV: XX
	SHEET: 1 OF XX	(Signature/Stamp)	

D

C

B

A

D

C

B

A

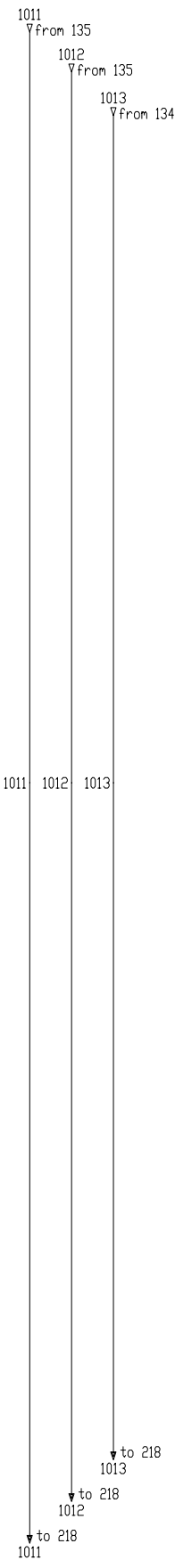

THIS SPACE INTENTIONALLY LEFT BLANK

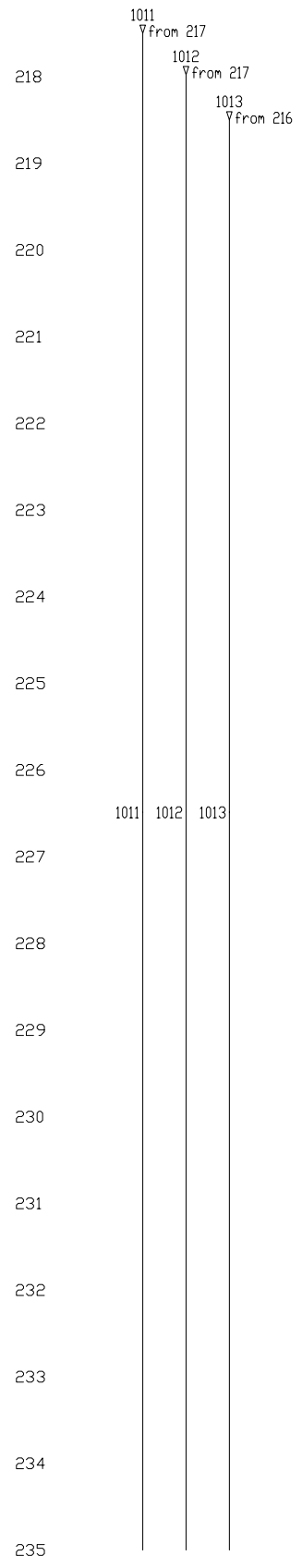

THIS SPACE INTENTIONALLY LEFT BLANK

XXXX XXXXXXXX XX XXX XXXXXXXXXXXX XX XXXXXXXXXXXX XXXXXXXXXXXX XX XXX XXXXXXXXXXXXXXXXXXXXXXXXXXXX XXXXXX XX XXXXXXXXXXXXXXXXXXXX XXX XXX XXXXXXX XXXXXXX XX XXXXXXXXXXXX	XXXXXX_XXXX XXXXXX	SIMPLE SAFETY SINGLE SAFETY GATE POWER DISTRIBUTION		DWG XX	DATE 10-17-08
		DWT	SHEET 2 OF XX	DWG REV EXAMPLE	XX

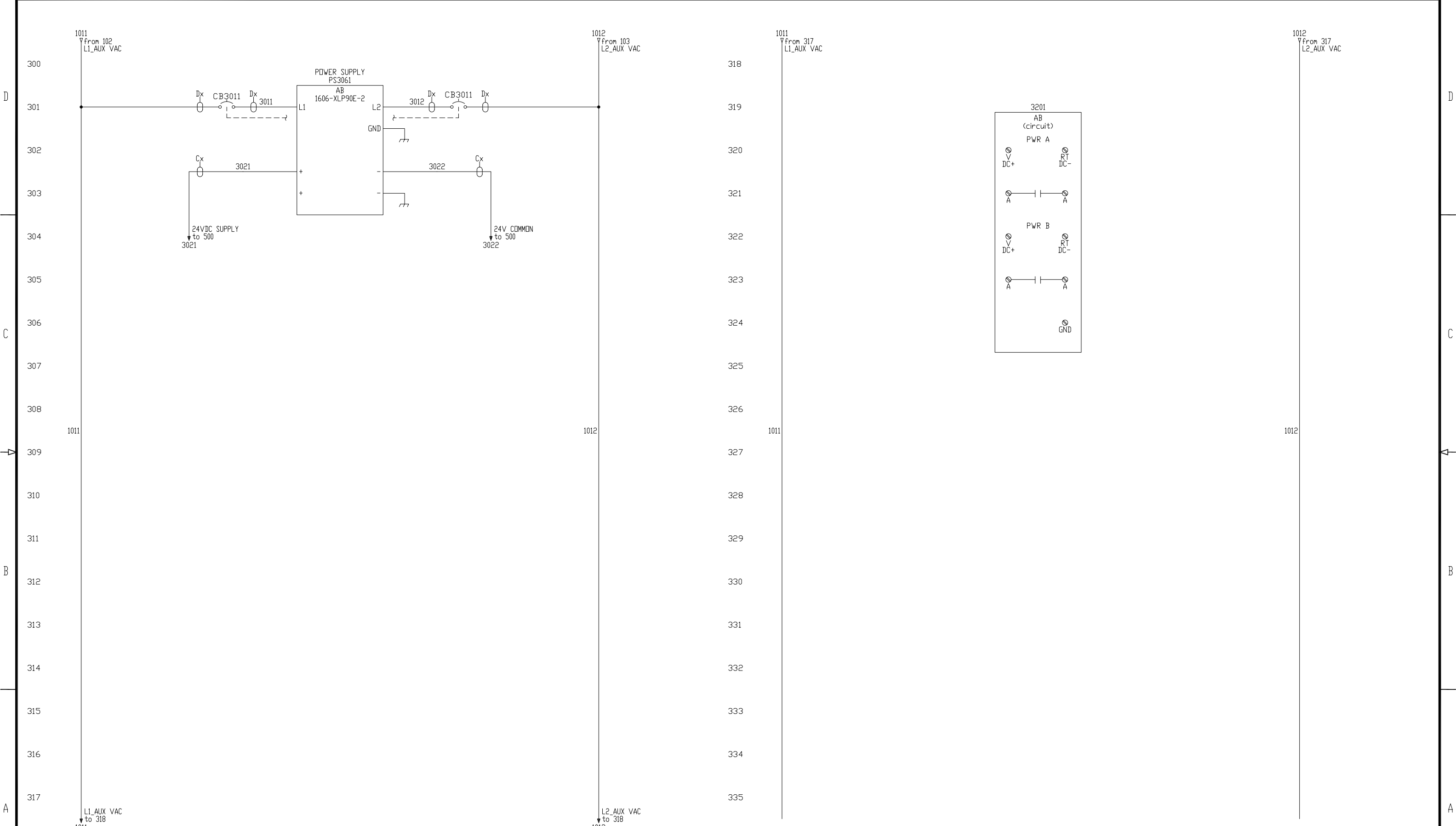

NOTES:
 1. ALL WIRES TO BE xxxV, xx*, xxx.
 2. OBSERVE DIRTY/CLEAN WIRING PRACTICES.
 3. Dx/Cx MARKERS INDICATE POTENTIAL ROUTING WIRING.
 4. ALL WIRES ARE #xx AWG, UNLESS OTHERWISE NOTED.
 5. ALL WIRES ARE xxx, UNLESS OTHERWISE NOTED.
 6. ALL GROUND WIRES ARE #xx AWG xxxxxx, UNLESS OTHERWISE NOTED.

XXXX XXXXXXXX XX XXX XXXXXXXXXXXX XX XXXXXXXXXXXX XXXXXXXXXXXXXXXX XX XXX XXXXXXXXXXXXXXXX XXXXXXXXXXXX XXXXXXXX XX XXXXXXXXXXXXXXXX XXX XXX XXXXXXXX XXXXXXXX XX XXXXXXXXXXXXXXXX	XXXXXX_XXXX XXXXXX	SIMPLE SAFETY SINGLE SAFETY GATE 460VAC CONTROL	DWG XX DATE 10-17-08 EXAMPLE XX	DWG REV XX
			SHEET 3 OF XX	(C/A)

D

C

B

A

D

C

B

A

1013
from 105
VAC CONTROL

N
from 106
VAC NEUTRAL

1013
from 417
VAC CONTROL

N
from 417
VAC NEUTRAL

400
401
402
403
404
405
406
407
408
409
410
411
412
413
414
415
416
417

418
419
420
421
422
423
424
425
426
427
428
429
430
431
432
433
434
435

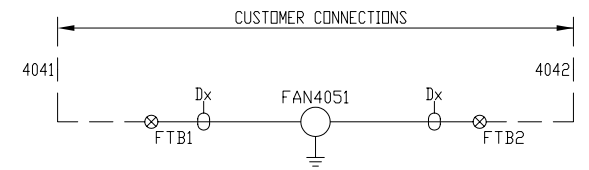

THIS SPACE INTENTIONALLY LEFT BLANK

1013

N

1013

N

VAC CONTROL
to 418
1013

VAC NEUTRAL
to 418
N

- NOTES:
1. ALL WIRES TO BE xxxV, xx*, xxx.
 2. OBSERVE DIRTY/CLEAN WIRING PRACTICES.
 3. Dx/Cx MARKERS INDICATE POTENTIAL ROUTING WIRING.
 4. ALL WIRES ARE #xx AWG, UNLESS OTHERWISE NOTED.
 5. ALL WIRES ARE xxx, UNLESS OTHERWISE NOTED.
 6. ALL GROUND WIRES ARE #xx AWG xxxxxx, UNLESS OTHERWISE NOTED.

XXXXX_XXXX XXXXXX	SIMPLE SAFETY SINGLE SAFETY GATE AUX VAC CONTROL		DWG XX	DATE 10-17-08
	DWG ID EXAMPLE DWG REV XX		DIST	SHEET 4 OF XX

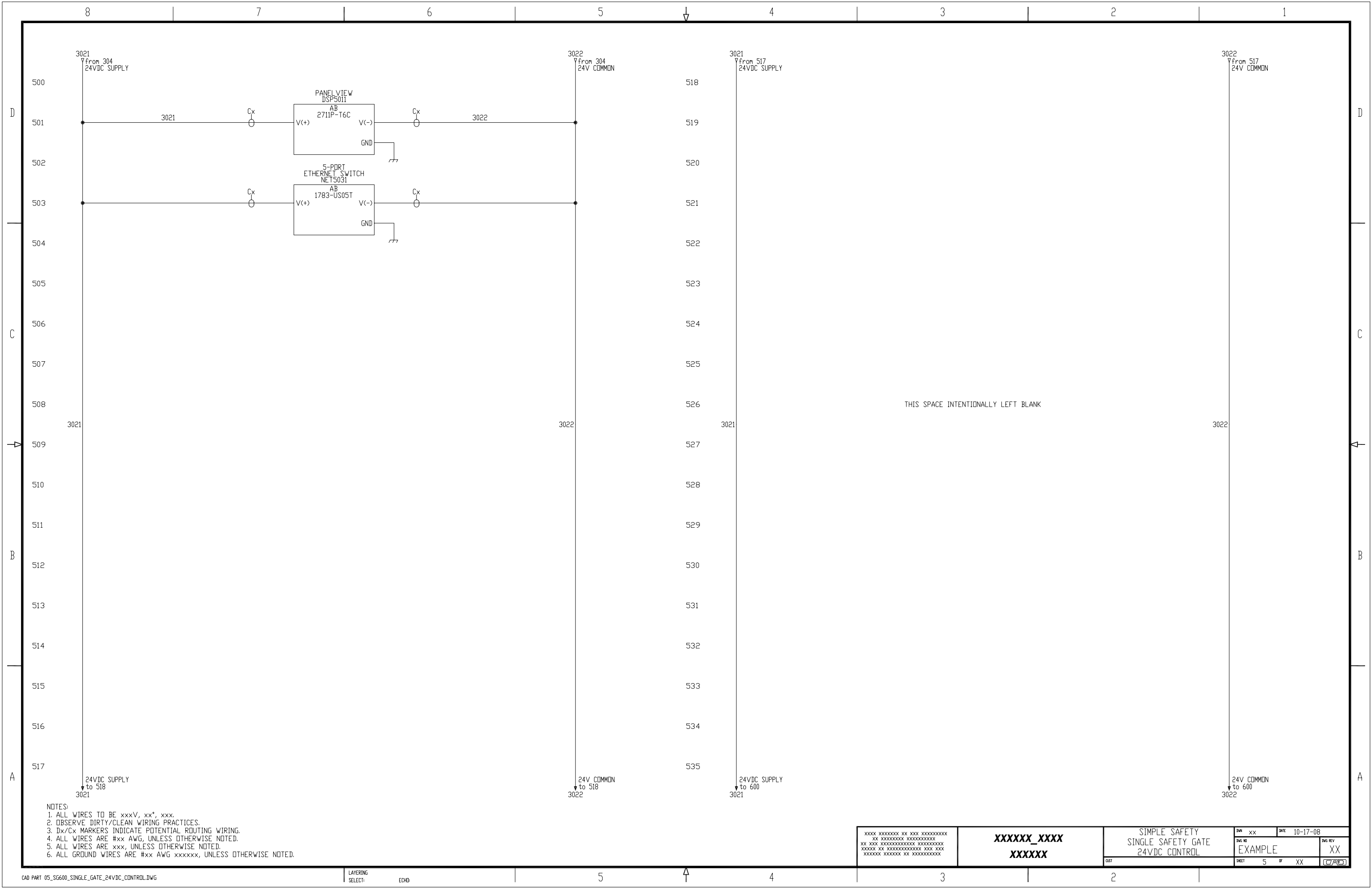

- NOTES:
1. ALL WIRES TO BE xxxV, xx*, xxx.
 2. OBSERVE DIRTY/CLEAN WIRING PRACTICES.
 3. Dx/Cx MARKERS INDICATE POTENTIAL ROUTING WIRING.
 4. ALL WIRES ARE #xx AWG, UNLESS OTHERWISE NOTED.
 5. ALL WIRES ARE xxx, UNLESS OTHERWISE NOTED.
 6. ALL GROUND WIRES ARE #xx AWG xxxxxx, UNLESS OTHERWISE NOTED.

XXXXX_XXXX XXXXX	SIMPLE SAFETY SINGLE SAFETY GATE 24VDC CONTROL		DWG NO EXAMPLE	DATE 10-17-08	DWG REV XX
			SHEET 5	OF XX	(C/A/C)

8

7

6

5

4

3

2

1

D

D

C

C

B

B

A

A

3021
from 535
24VDC SUPPLY

3022
from 535
24V COMMON

3021
from 617
24VDC SUPPLY

3022
from 617
24V COMMON

600
601
602
603
604
605
606
607
608
609
610
611
612
613
614
615
616
617

618
619
620
621
622
623
624
625
626
627
628
629
630
631
632
633
634
635

THIS SPACE INTENTIONALLY LEFT BLANK

THIS SPACE INTENTIONALLY LEFT BLANK

3021

3022

3021

3022

24VDC SUPPLY
to 618
3021

24V COMMON
to 618
3022

24VDC SUPPLY
to 700
3021

24V COMMON
to 700
3022

- NOTES:
1. ALL WIRES TO BE xxxV, xx*, xxx.
 2. OBSERVE DIRTY/CLEAN WIRING PRACTICES.
 3. Dx/Cx MARKERS INDICATE POTENTIAL ROUTING WIRING.
 4. ALL WIRES ARE #xx AWG, UNLESS OTHERWISE NOTED.
 5. ALL WIRES ARE xxx, UNLESS OTHERWISE NOTED.
 6. ALL GROUND WIRES ARE #xx AWG xxxxxx, UNLESS OTHERWISE NOTED.

XXXX XXXXXXXX XX XXX XXXXXXXXXXXX
XX XXXXXXXXXXXX XXXXXXXXXXXX
XX XXX XXXXXXXXXXXX XXXXXXXXXXXX
XXXXXXXX XX XXXXXXXXXXXX XXX XXX
XXXXXXXX XXXXXXXX XX XXXXXXXXXXXX

XXXXXX_XXXX
XXXXXX

SIMPLE SAFETY
SINGLE SAFETY GATE
SAFETY SPARE

DWG	XX	DATE	10-17-08
DWG NO	EXAMPLE		DWG REV
		XX	
SHEET	6	OF	XX

5

4

3

2

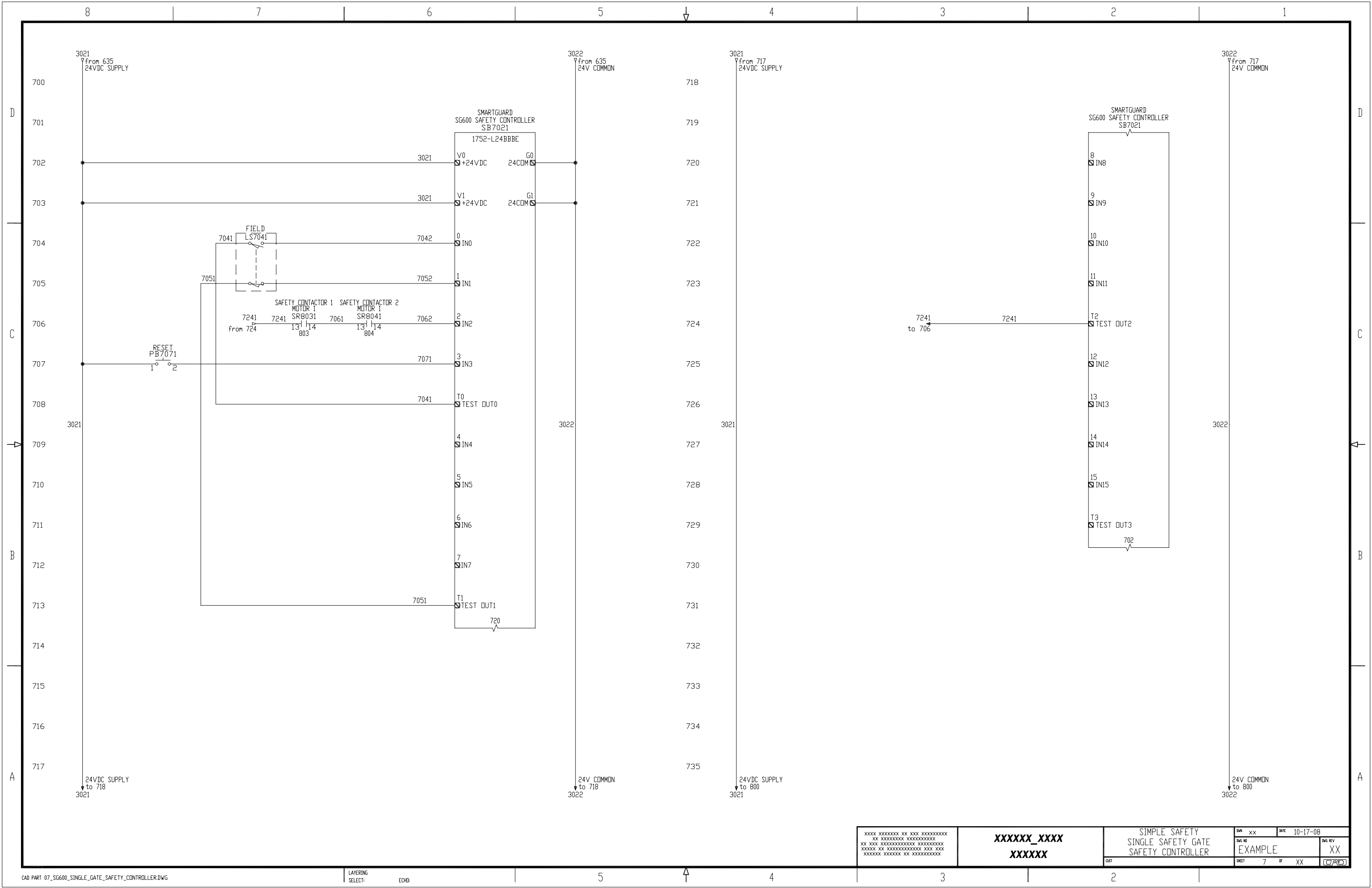

XXXX XXXXXXXX XX XXX XXXXXXXXXXXX XX XXXXXXXXXXXX XXXXXXXXXXXX XX XXX XXXXXXXXXXXX XXXXXXXXXXXX XXXXXX XX XXXXXXXXXXXX XXX XXX XXXXXXX XXXXXXX XX XXXXXXXXXXXX	XXXXXX_XXXX XXXXXX	SIMPLE SAFETY SINGLE SAFETY GATE SAFETY CONTROLLER	DWG XX DATE 10-17-08 DWT SHEET 7 OF XX	DWT REV XX EXAMPLE (C/A/C)
--	-------------------------------------	--	--	----------------------------------

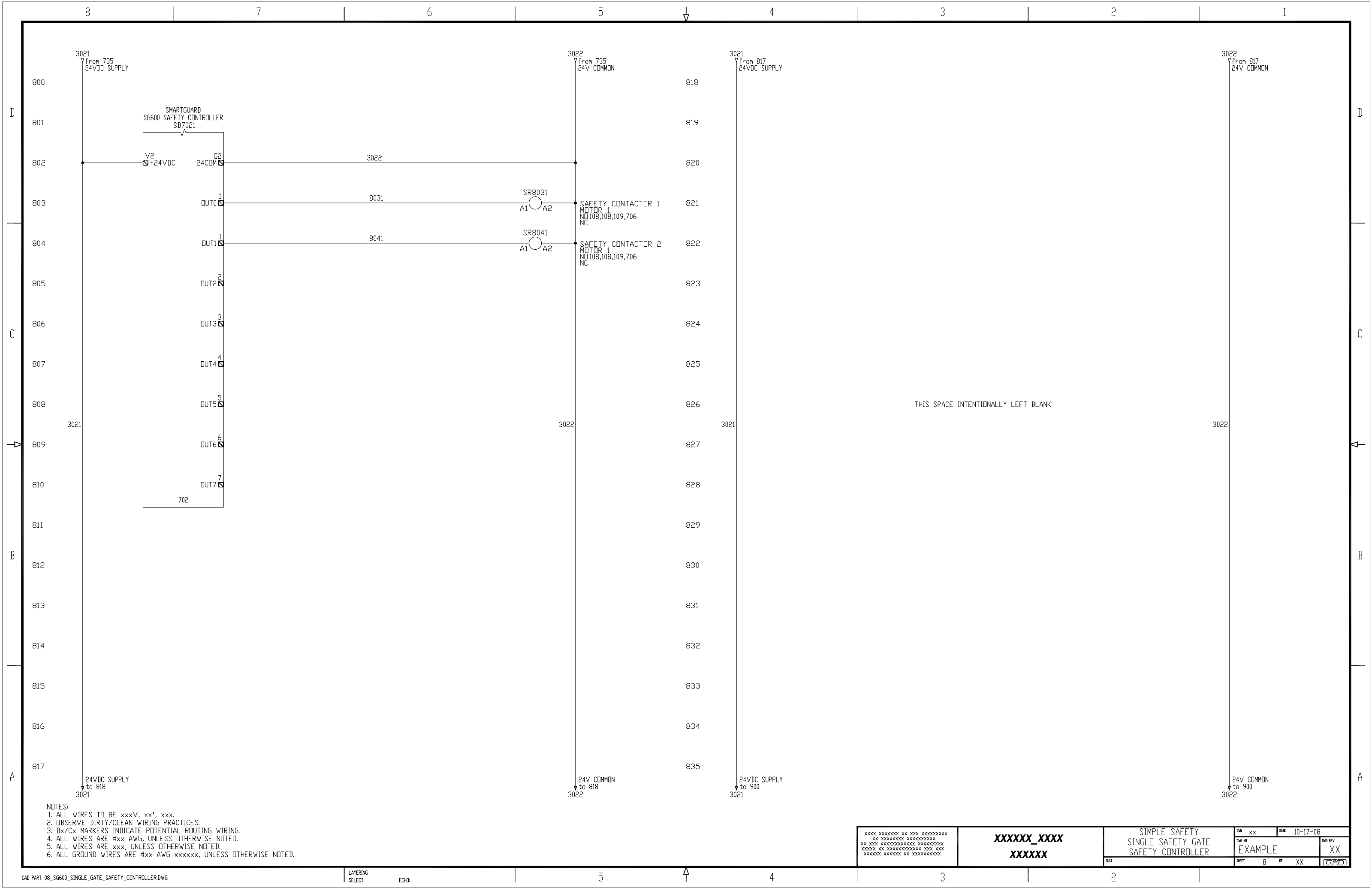

XXXX XXXXXXXX XX XXX XXXXXXXXXX XX XXXXXXXXXX XXXXXXXXXX XX XXX XXXXXXXXXX XXXXXXXXXX XXXXXX XX XXXXXXXXXX XXX XXX XXXXXX XXXXXX XX XXXXXXXXXX	XXXXXX_XXXX XXXXXX	SIMPLE SAFETY SINGLE SAFETY GATE SAFETY CONTROLLER	DWG XX DATE 10-17-08 DWG REV EXAMPLE XX	DWG REV XX
			SHEET 8 OF XX	

8

7

6

5

4

3

2

1

3021
from 835
24VDC SUPPLY

3022
from 835
24V COMMON

3021
from 917
24VDC SUPPLY

3022
from 917
24V COMMON

900
901
902
903
904
905
906
907
908
909
910
911
912
913
914
915
916
917

918
919
920
921
922
923
924
925
926
927
928
929
930
931
932
933
934
935

918
919
920
921
922
923
924
925
926
927
928
929
930
931
932
933
934
935

THIS SPACE INTENTIONALLY LEFT BLANK

THIS SPACE INTENTIONALLY LEFT BLANK

3021

3022

3021

3022

24VDC SUPPLY
to 918
3021

24V COMMON
to 918
3022

24VDC SUPPLY
to 1000
3021

24V COMMON
to 1000
3022

- NOTES:
1. ALL WIRES TO BE xxxV, xx*, xxx.
 2. OBSERVE DIRTY/CLEAN WIRING PRACTICES.
 3. Dx/Cx MARKERS INDICATE POTENTIAL ROUTING WIRING.
 4. ALL WIRES ARE #xx AWG, UNLESS OTHERWISE NOTED.
 5. ALL WIRES ARE xxx, UNLESS OTHERWISE NOTED.
 6. ALL GROUND WIRES ARE #xx AWG xxxxxx, UNLESS OTHERWISE NOTED.

XXXX XXXXXXXX XX XXX XXXXXXXXXXXX
XX XXXXXXXXXXXX XXXXXXXXXXXX
XX XXX XXXXXXXXXXXX XXXXXXXXXXXX
XXXXXXXX XX XXXXXXXXXXXX XXX XXX
XXXXXXXX XXXXXXXX XX XXXXXXXXXXXX

XXXXXX_XXXX
XXXXXX

SIMPLE SAFETY
SINGLE SAFETY GATE
DRIVE SPARE

DWG	XX	DATE	10-17-08
DWG NO	EXAMPLE	DWG REV	XX
SHEET	9	OF	XX

5

4

3

2

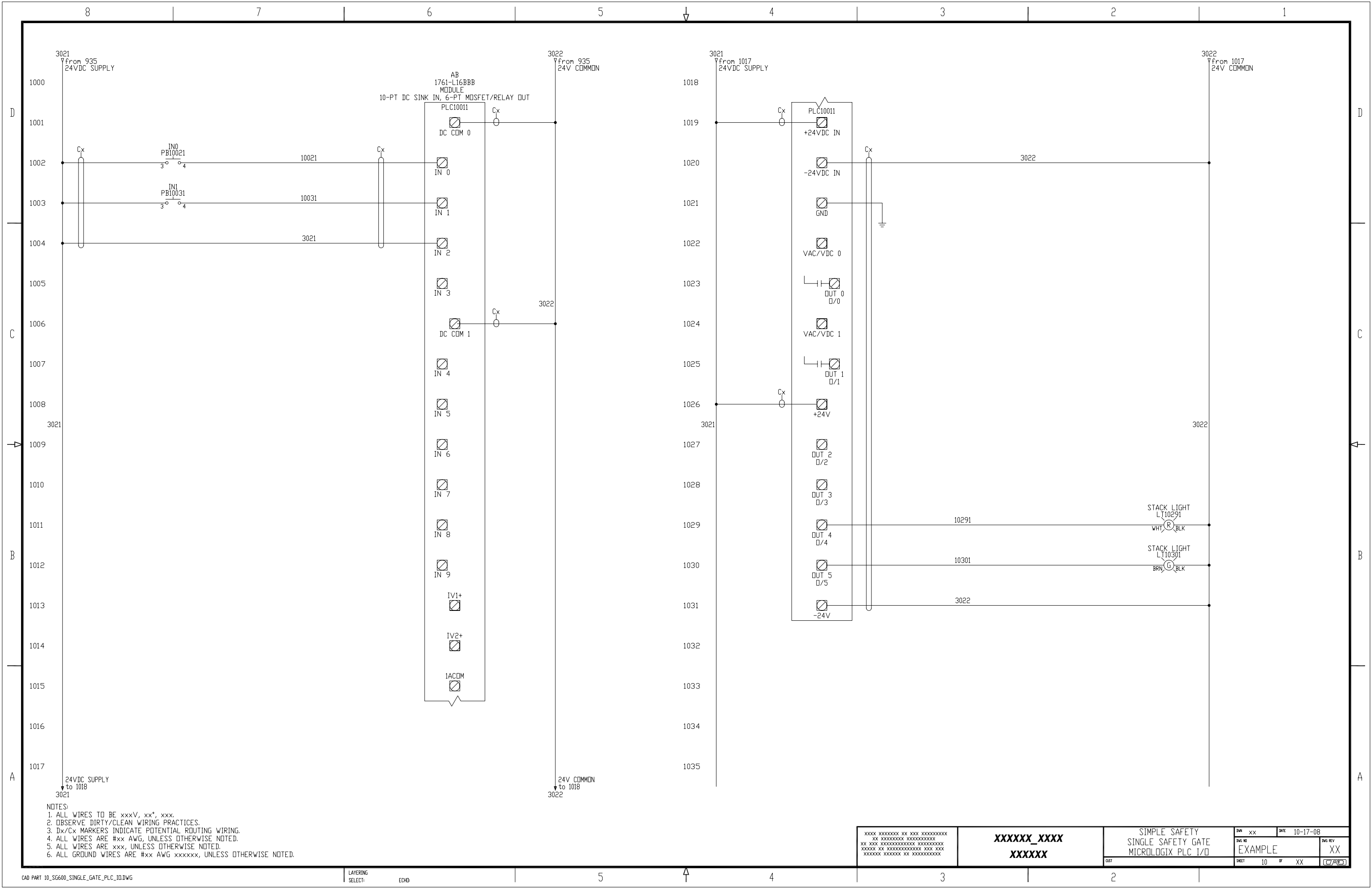

- NOTES:
1. ALL WIRES TO BE xxxV, xx*, xxx.
 2. OBSERVE DIRTY/CLEAN WIRING PRACTICES.
 3. Dx/Cx MARKERS INDICATE POTENTIAL ROUTING WIRING.
 4. ALL WIRES ARE #xx AWG, UNLESS OTHERWISE NOTED.
 5. ALL WIRES ARE xxx, UNLESS OTHERWISE NOTED.
 6. ALL GROUND WIRES ARE #xx AWG xxxxxx, UNLESS OTHERWISE NOTED.

XXXX XXXXXXXX XX XXX XXXXXXXXXXXX XX XXXXXXXXXXXX XXXXXXXXXXXX XXXXXX XX XXXXXXXXXXXX XXX XXX XXXXXXXX XXXXXX XX XXXXXXXXXXXX	XXXXXX_XXXX XXXXXX	SIMPLE SAFETY SINGLE SAFETY GATE MICROLOGIX PLC I/O	DWG XX DATE 10-17-08 EXAMPLE XX	DWG REV XX
			SHEET 10 OF XX	

8

7

6

5

4

3

2

1

D

D

1100

1118

1101

1119

1102

1120

1103

1121

1104

1122

1105

1123

C

C

1106

1124

1107

1125

1108

THIS SPACE INTENTIONALLY LEFT BLANK

1126

THIS SPACE INTENTIONALLY LEFT BLANK

B

B

1109

1127

1110

1128

1111

1129

A

A

1112

1130

1113

1131

1114

1132

1115

1133

1116

1134

1117

1135

XXXX XXXXXXXX XX XXX XXXXXXXXXXXX
XX XXXXXXXXXXXX XXXXXXXXXXXX
XX XXX XXXXXXXXXXXX XXXXXXXXXXXX
XXXXXXXX XX XXXXXXXXXXXX XXX XXX
XXXXXXXX XXXXXXXX XX XXXXXXXXXXXX

XXXXXX_XXXX
XXXXXX

SIMPLE SAFETY
SINGLE SAFETY GATE
PLC I/O SPARE

DWG NO XX DATE 10-17-08
DWG REV EXAMPLE XX

SHEET 11 OF XX

CPD

HMI PANELVIEW 600C
2711C-T6C

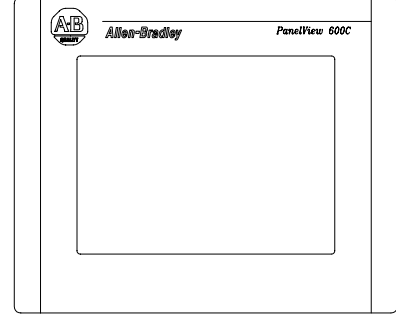

5PORT ETHERNET
SWITCH
1783-US05T

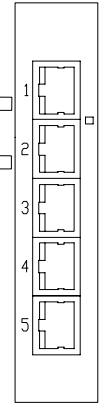

SMARTGUARD 600 w/ETHERNET
1752-L24BBBE

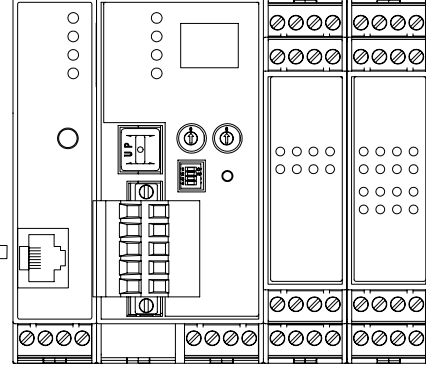

MICROLOGIX 1100
1763-L16BBB

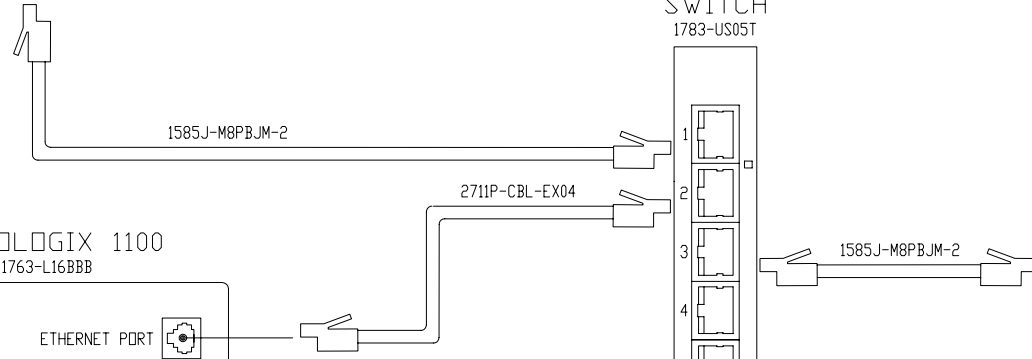
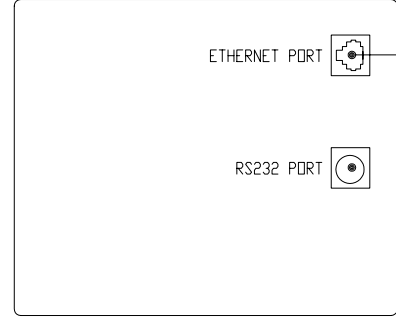

XXXX XXXXXXXX XX XXX XXXXXXXXXXXX XX XXXXXXXXXXXX XXXXXXXXXXXX XX XXX XXXXXXXXXXXX XXXXXXXXXXXX XXXXXXXX XX XXXXXXXXXXXX XXX XXX XXXXXXXX XXXXXXXX XX XXXXXXXXXXXX	XXXXXX_XXXX XXXXXX	SIMPLE SAFETY SINGLE SAFETY GATE COMMUNICATION DIAGRAM	DWG XX DATE 10-17-08	DWG REV XX
			SHEET 12 OF XX	

D
C
B
A

D
C
B
A

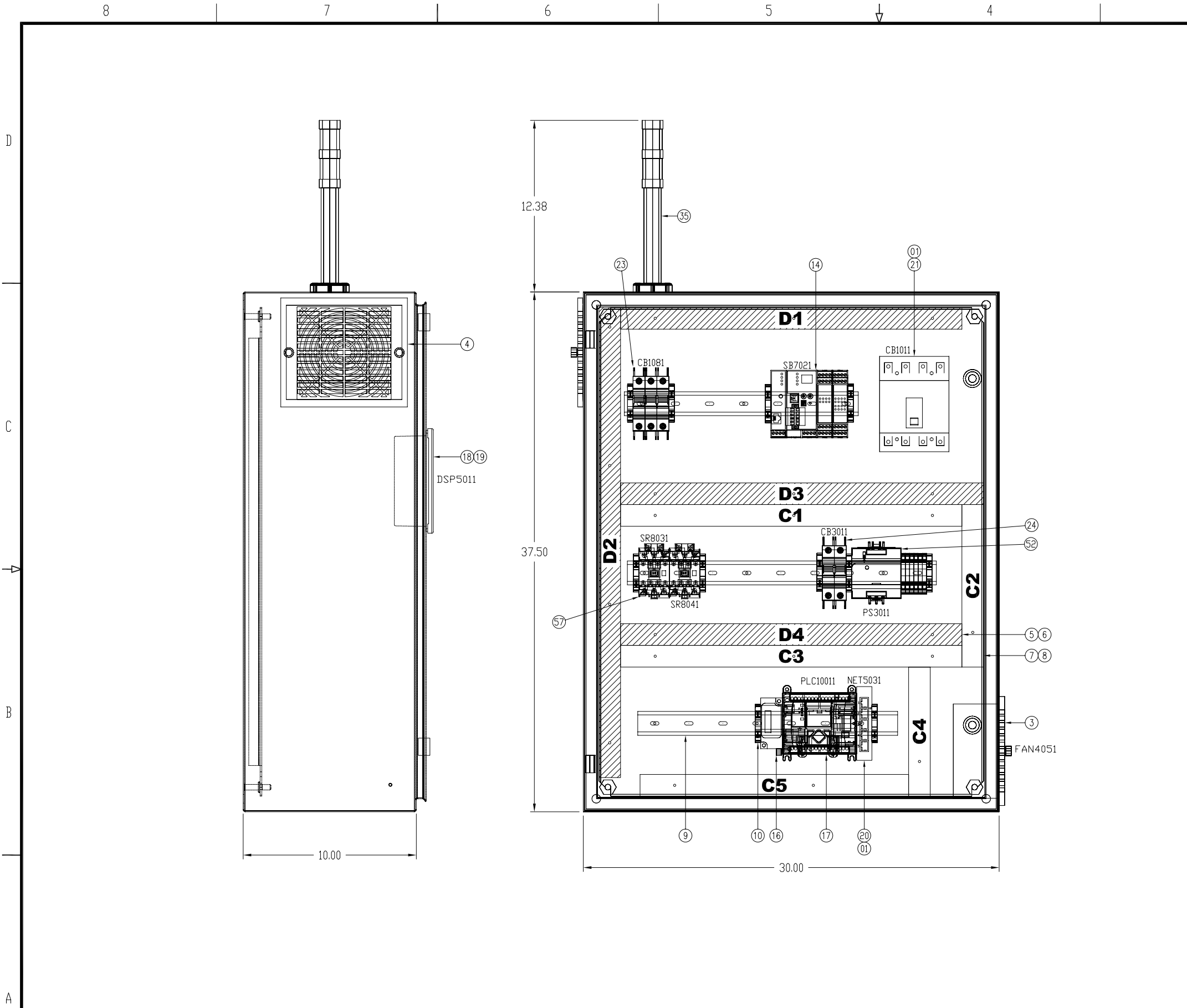

ITEM	QTY	DESCRIPTION	MFG	CATALOG
1	1	NEMA1 ENCLOSURE 30"x24"x10"	HOFFMAN	CSD302410
2	1	PANEL FOR ENCLOSURE 21"x22.5"	HOFFMAN	CP3024
3	1	FAN KIT 115VAC WITH FILTER	HOFFMAN	TFP41
4	1	EXHAUST GRILL WITH FILTER	HOFFMAN	TEP4
5	-	PANDUIT WIRE DUCT, 1"x4" GRAY	PANDUIT	F1X4LG6
6	-	PANDUIT WIRE DUCT COVER, 1" GRAY	PANDUIT	C1LG6
7	-	PANDUIT WIRE DUCT, 1" X4" WHITE	PANDUIT	F1X4WH6
8	-	PANDUIT WIRE DUCT COVER, 1" WHITE	PANDUIT	C1WH6
9	-	35MM DIN RAIL	AB	199-DR1
10	9	END ANCHOR USED W/STANDARD 35MM DIN	AB	1492-EAJ35
11	-	-	-	-
12	-	-	-	-
13	-	-	-	-
14	1	SMARTGUARD 600 SMALL SAFETY CONTROLLER w/ETHERNET	AB	1752-L24BBB
CONTROL AND VISUALIZATION EQUIPMENT				
15	1	1763 MICROLOGIX 1100 SYSTEM GROUP SELECTION		
16	1	CABLE: MICROLOGIX 1100 CHANNEL 0 TO RS-485	AB	1763-NC01
17	1	MICROLOGIX 1100, 24V DC POWER	AB	1763-L16BBB
18	1	6" COLOR (TRANSMISSIVE CSTN) TOUCHSCREEN	AB	2711C-T6C
19	2	1585 ETHERNET CABLE, TEAL RISER PVC, 2 METER	AB	1585J-M8PBJM-2
20	1	STRATIX 2000 SWITCH, UNMANAGED, 5 COPPER PORTS	AB	1783-US05T
POWER CIRCUIT COMPONENTS				
380 VAC - 480 VAC, 4 POLE C.B. DISCONNECT OPTION				
21	1	IEC MOLDED CASE C.B., 160A, H-FRAME, RATED 32A	AB	140UE-H2E4-C32
22	1	ROTARY, VARIABLE-DEPTH OPERATING MECHANISM	AB	140U-H-RVM12R
23	1	UL489/CSA 22.2 NO 5.1 CIRCUIT BREAKER, 3 POLE, 7 AMP	AB	1489-A3C070
24	1	UL489/CSA 22.2 NO 5.1 CIRCUIT BREAKER, 2 POLE10 AMP	AB	1489-A2D100
380/400 VAC, 3 POLE FUSED DISCONNECT OPTION				
25	1	194R DISCONNECT, OPEN STYLE, DIN, 32A, 3 POLE	AB	194R-D32-1753
26	1	OPERATING HANDLE, WITH DEFEATER, RED/YELLOW	AB	194R-HS4E
27	1	OPERATING SHAFT, STANDARD LENGTH, 263MM (10.3 IN.)	AB	194R-R1
28	1	UL489/CSA 22.2 NO 5.1 CIRCUIT BREAKER, 3 POLE, 7 AMP	AB	1489-A3C070
29	1	UL489/CSA 22.2 NO 5.1 CIRCUIT BREAKER, 2 POLE, 10 AMP	AB	1489-A2D100
480 VAC, 3 POLE FUSED DISCONNECT OPTION				
30	1	194R DISCONNECT, OPEN STYLE, 30A, 3 POLE	AB	194R-C30-1753
31	1	OPERATING HANDLE, WITH DEFEATER, RED/YELLOW	AB	194R-HS4E
32	1	OPERATING SHAFT, STANDARD LENGTH, 263MM (10.3 IN.)	AB	194R-R1
33	1	UL489/CSA 22.2 NO 5.1 CIRCUIT BREAKER, 3 POLE, 7 AMP	AB	1489-A3C070
34	1	UL489/CSA 22.2 NO 5.1 CIRCUIT BREAKER, 2 POLE, 10 AMP	AB	1489-A2D100
SENSORS/STACKLIGHTS				
35	1	COMPACT TOWER LIGHT, 30 MM, GRN, RED LED	AB	855D-P25SC20G24Y3Y4
36	1	PHOTOSWITCH PHOTOELECTRIC SENSOR, RIGHTSIGHT	AB	42EF-P2MPB-F4
37	1	60-2695 BRACKET, (USE W/ 60-2439, 60-2649)	AB	60-2695
38	1	PATCHCORD: DC MICRO (M12), FEMALE, STRAIGHT, 4-PIN	AB	889D-F4ACDM-2
39	1	RECEPTACLE, DC MICRO (M12), FEMALE, STRAIGHT, 4-PIN	AB	888D-F4AC1-1
PUSHBUTTONS				
40	1	800F 3 POSITION S.S. - PLASTIC, MAINTAINED, BLACK	AB	800FP-SM32
41	1	800F LEGEND PLATE, ENGLISH: AUTO - OFF - HAND	AB	800F-11WE104
42	2	22.5MM PB NO LATCH, SCREW CONTACT BLOCK, 1 N.O.	AB	800F-X10
43	1	PLASTIC LATCH	AB	800F-ALP
44	1	800F PUSH BUTTON - PLASTIC, FLUSH, GREEN, I	AB	800FP-F306
45	1	PLASTIC LATCH	AB	800F-ALP
46	1	22.5MM PB NO LATCH, SCREW CONTACT BLOCK, 1 N.O.	AB	800F-X10
47	1	800F PUSH BUTTON - PLASTIC, EXTENDED, RED, O	AB	800FP-E405
48	1	PLASTIC LATCH	AB	800F-ALP
49	1	22.5MM PB NO LATCH, SCREW CONTACT BLOCK, 1 N.O.	AB	800F-X10
PROGRAMMING SOFTWARE				
50	1	RSNETWORKX FOR DEVICENET	AB	9357-DNETL3
51	1	RSLOGIX MICRO STARTER (ENGLISH) CD-ROM	AB	9324-RLM0100ENE

NOTES:
 1. WIREWAYS MARKED Cx/Dx INDICATE CLEAN/DIRTY SIGNAL/POWER
 2. FOR FURTHER INFORMATION ON SYSTEM DESIGN FOR CONTROL OF ELECTRICAL NOISE SEE ROCKWELL PUBLICATION #GMC RM001-EN-P

XXXX XXXXXXXX XX XXX XXXXXXXXXX XX XXX XXXXXXXXXXXXXXXXXXXXXXXX XXXXXXXX XX XXXXXXXXXXXXXXXXXXXX XXXXXXXX XXXXXXX XXX XXXXXXXXXX	XXXXXX_XXXX XXXXXX	SIMPLE SAFETY SINGLE SAFETY GATE PANEL LAYOUT	DWG NO EXAMPLE	DATE 10-17-08	DWG REV XX
			SHEET 13	OF XX	DATE 10-17-08

8

7

6

5

4

3

2

1

ADDITIONAL PARTS LIST

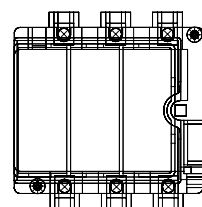

30 30A FUSED DISCONNECT

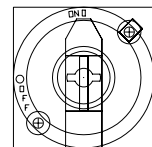

22 ROTARY VARIABLE DEPTH MECHANISM

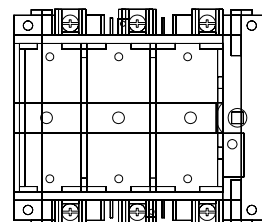

25 60A FUSED DISCONNECT

CONTROL CIRCUIT COMPONENTS				
52	1	1606-XLP90E-2: COMPACT PWS, 24-28V, 90 W, 480VAC	AB	1606-XLP90E-2
E-STOP PUSHBUTTON				
53	1	800F NON-ILLUMINATED MUSHROOM, TWIST TO RELEASE	AB	800FP-MT44
54	1	PLASTIC LATCH	AB	800F-ALP
55	1	22.5MM PB NO LATCH, SCREW CONTACT BLOCK, 2 N.C.T	AB	800F-X02D
SINGLE ZONE SAFETY GATE EQUIPEMENT EQUIPMENT				
56	2	LARGE METAL ROLLER PLUNGER, 1 NO & 1 NC, 1/2IN NPT	AB	440P-MRPS11E
57	2	MCS 100S-C SAFETY CONTACTOR, 9A, 24V DC	AB	100S-C09DJ05C
58	1	800F RESET, ROUND METAL (TYPE 4/13, IP66), BLUE, R	AB	800FM-R611

D

D

C

C

B

B

A

A

5

4

3

2

XXXX XXXXXXXX XX XXX XXXXXXXXXXXX
XX XXXXXXXXXXXX XXXXXXXXXXXX
XX XXX XXXXXXXXXXXX XXXXXXXXXXXX
XXXXXXXX XX XXXXXXXXXXXX XXX XXX
XXXXXXXX XXXXXXXX XX XXXXXXXXXXXX

XXXXXX_XXXX
XXXXXX

SIMPLE SAFETY
SINGLE SAFETY GATE
ADDITIONAL PARTS

DWG XX DATE 11-07-08

DWG REV
EXAMPLE

DWG REV
XX

SHEET

14

OF

XX

(PAC)

8 7 6 5 4 3 2 1

D

C

B

A

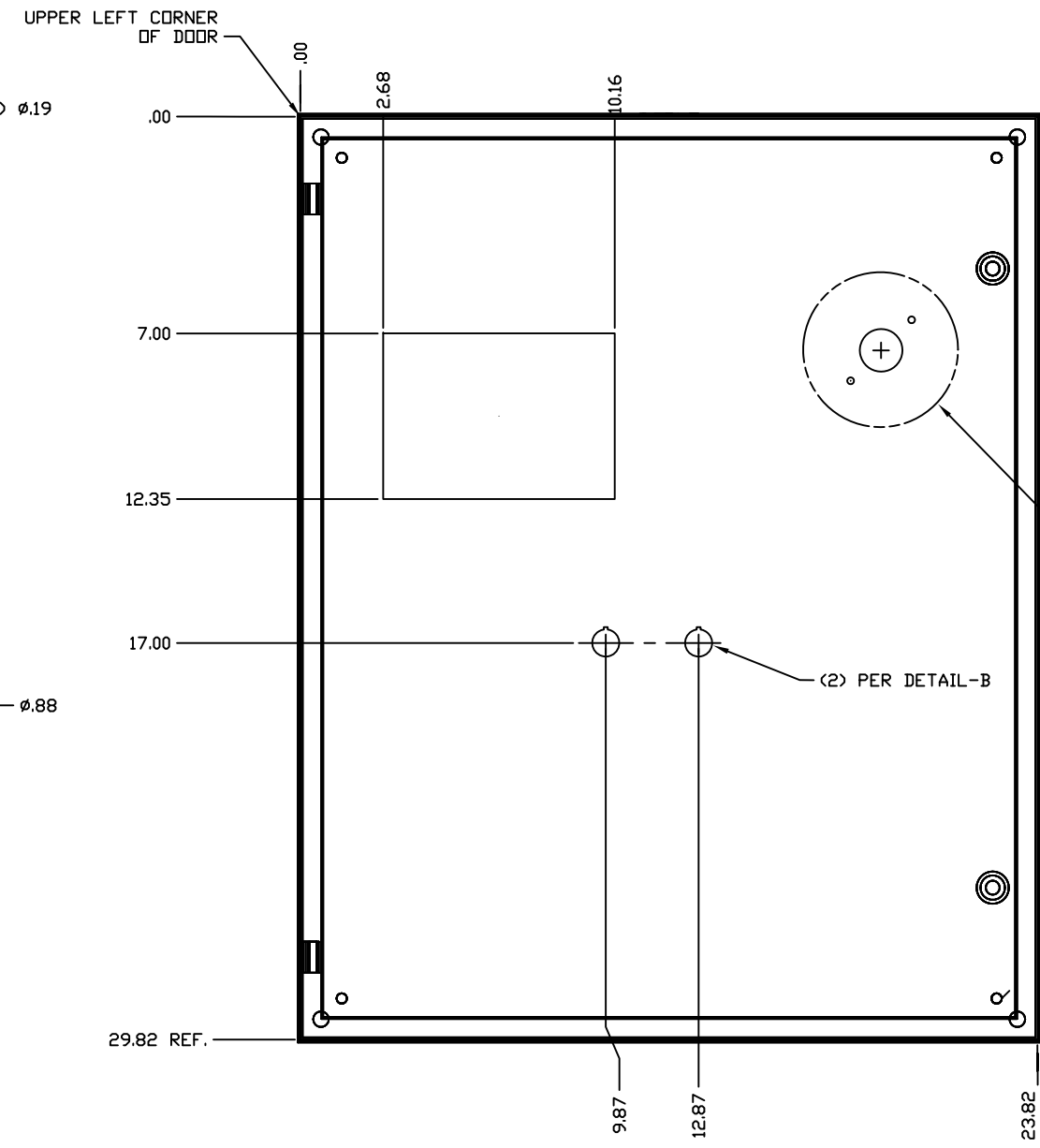
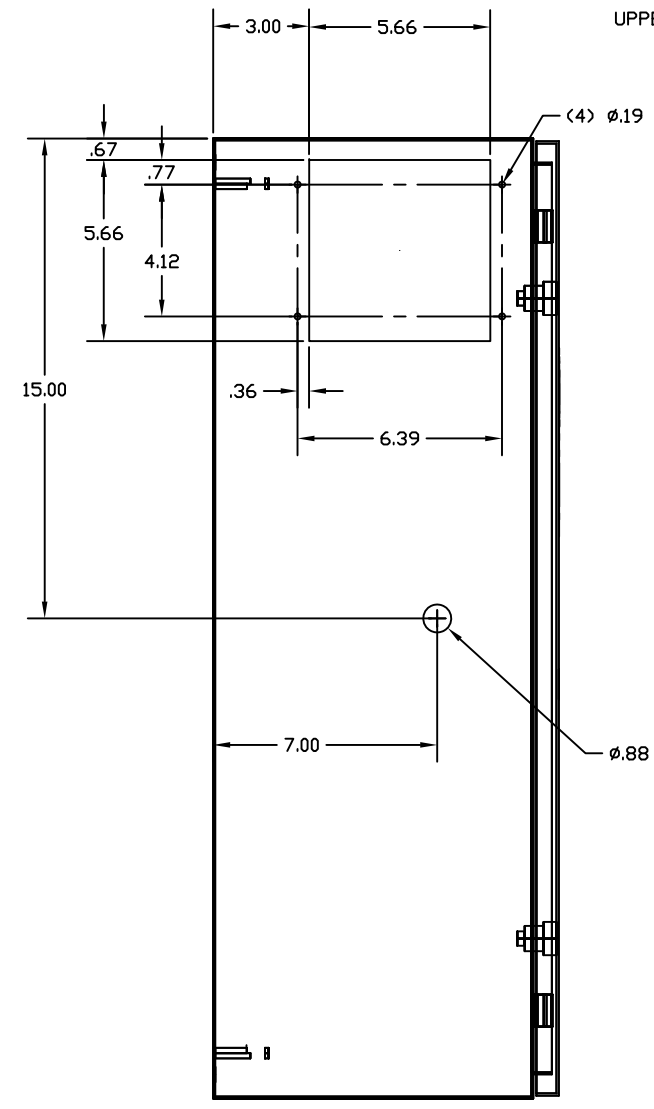
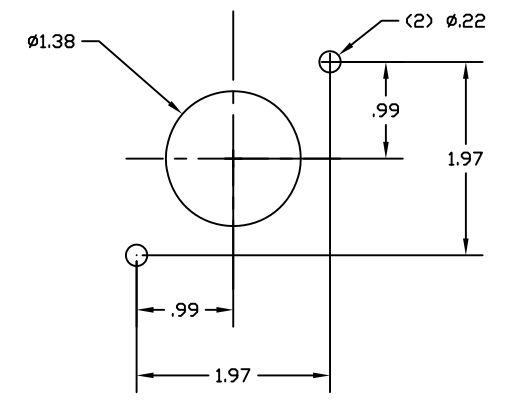
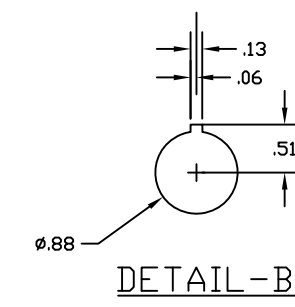
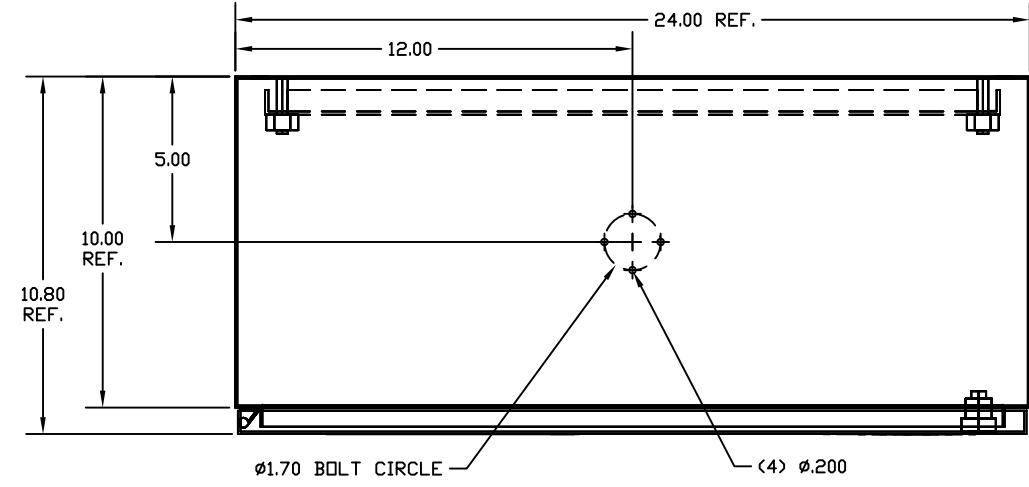

PER DETAIL-A,
(SEE SHEET 2 FOR ALL
OPERATOR OPTION
LOCATIONS)

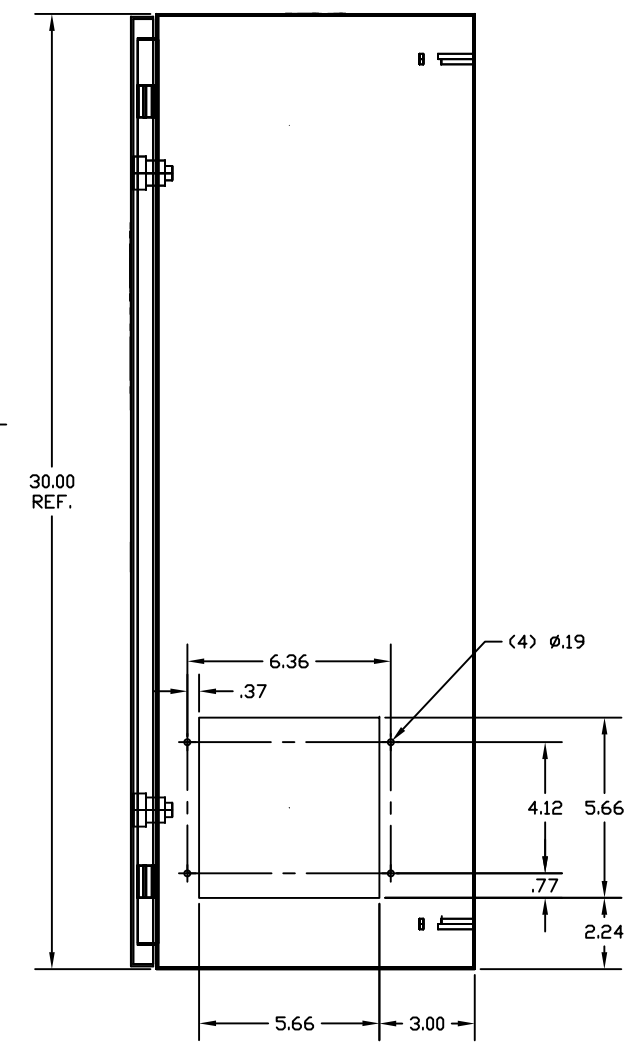

DOOR MODIFICATION

-01	1	HOFFMAN PART CSD302410	ANSI 61 GRAY
PART NO.	CHG. CHAR.	MATERIAL	SURFACE TREATMENT

LAYERING SELECT: ECHD

XXXX XXXXXXXX XX XX XXXXXXXXXXXX XX XXXXXXXXXXXX XXXXXXXXXXXX XX XX XXXXXXXXXXXXXXX XXXXXXXXXXXX XXXXXXXX XX XXXXXXXXXXXXXXX XX XX XXXXXXXX XXXXXX XX XXXXXXXXXXXXXXX	XXXXXX_XXXX XXXXXX	SIMPLE SAFETY SINGLE SAFETY GATE ENCLOSURE DOOR LAYOUT	DWG XX DATE 10-17-08	DWG REV XX EXAMPLE	DWG REV XX DATE 15 OF XX
---	-----------------------	--	-------------------------	-----------------------	-----------------------------

8 7 6 5 4 3 2 1