

- NOTES:
1. ALL WIRES TO BE xxxV, xx*, xxx.
 2. OBSERVE DIRTY/CLEAN WIRING PRACTICES.
 3. Dx/Cx MARKERS INDICATE WIRE WAY ROUTING FOR THE SELECTED WIRES (Dx = DIRTY, Cx = CLEAN)
 4. ALL WIRES ARE #xx AWG, UNLESS OTHERWISE NOTED.
 5. ALL WIRES ARE xxx, UNLESS OTHERWISE NOTED.
 6. ALL GROUND WIRES ARE #xx AWG xxxxxxx, UNLESS OTHERWISE NOTED.

XXXXX_XXXX XXXXXX	CONNECTED COMPONENTS SINGLE DIR L-TYPE MUTING POWER DISTRIBUTION	DWG: XX DATE: 05-22-09
	EXAMPLE	DWG REV: A
SHEET: 1 OF XX		(C)

8

7

6

5

4

3

2

1

D

C

B

A

D

C

B

A

1071
Yfrom 135
1072
Yfrom 135
1073
Yfrom 134

1071 1072 1073

to 218
1073
to 218
1072
to 218
1071

THIS SPACE INTENTIONALLY LEFT BLANK

1071
Yfrom 217
1072
Yfrom 217
1073
Yfrom 216

1071 1072 1073

200
201
202
203
204
205
206
207
208
209
210
211
212
213
214
215
216
217

218
219
220
221
222
223
224
225
226
227
228
229
230
231
232
233
234
235

THIS SPACE INTENTIONALLY LEFT BLANK

XXXX XXXXXX XX XXX XXXXXXXXXX
XX XXXXXXXXXX XXXXXXXXXX
XX XXX XXXXXXXXXX XXXXXXXXXX
XXXXX XX XXXXXXXXXX XXX XXX
XXXXXX XXXXXX XX XXXXXXXXXX

XXXXXX_XXXX
XXXXXX

CONNECTED COMPONENTS
SINGLE DIR L-TYPE MUTING
POWER DISTRIBUTION

DWG NO	DATE	DWG REV
EXAMPLE	05-22-09	A

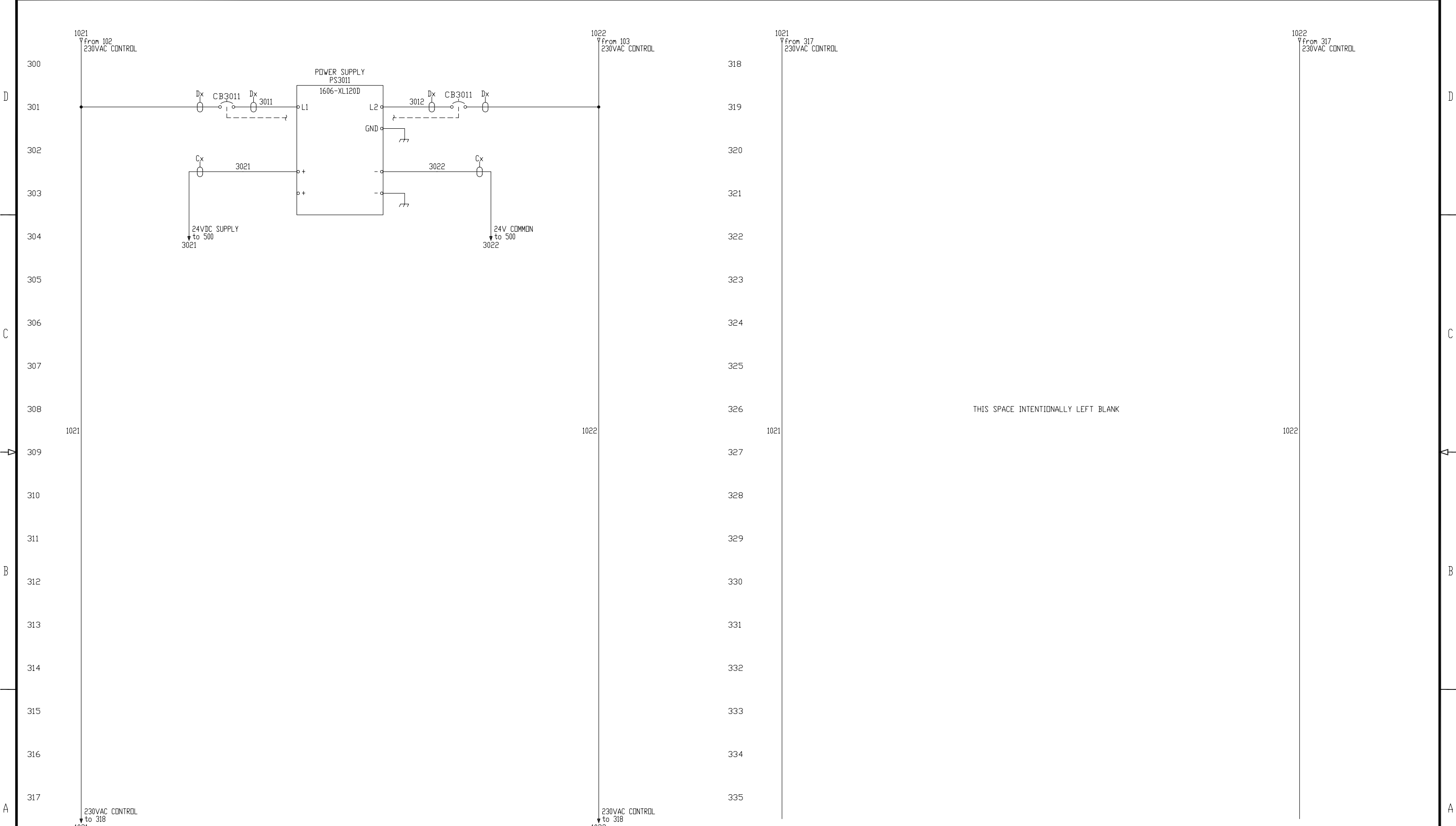

NOTES:
 1. ALL WIRES TO BE xxxV, xx*, xxx.
 2. OBSERVE DIRTY/CLEAN WIRING PRACTICES.
 3. Dx/Cx MARKERS INDICATE WIRE WAY ROUTING FOR THE SELECTED WIRES (Dx = DIRTY, Cx = CLEAN)
 4. ALL WIRES ARE #xx AWG, UNLESS OTHERWISE NOTED.
 5. ALL WIRES ARE xxx, UNLESS OTHERWISE NOTED.
 6. ALL GROUND WIRES ARE #xx AWG xxxxxx, UNLESS OTHERWISE NOTED.

XXXX XXXXXXXX XX XXX XXXXXXXXXXXX XX XXXXXXXXXXXX XXXXXXXXXXXXXXXX XX XXX XXXXXXXXXXXXXXXX XXXXXXXXXXXX XXXXXX XX XXXXXXXXXXXXXXXX XXX XXX XXXXXXX XXXXXXX XX XXXXXXXXXXXXXXX	XXXXXX_XXXX XXXXXX	CONNECTED COMPONENTS SINGLE DIR L-TYPE MUTING 230VAC CONTROL	DWG XX DATE 05-22-09
		DWG REV EXAMPLE A	SHEET 3 OF XX (C/A/C)

D

C

B

A

D

C

B

A

1053
from 106
120VAC CONTROL

1054
from 105
NEUTRAL

1053
from 417
120VAC CONTROL

1054
from 417
NEUTRAL

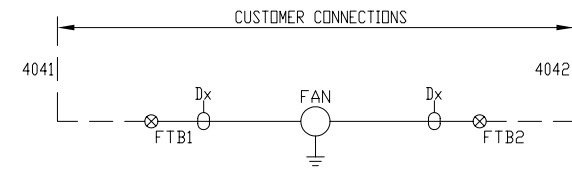

418
419
420
421
422
423
424
425
426
427
428
429
430
431
432
433
434
435

THIS SPACE INTENTIONALLY LEFT BLANK

1053

1054

1053

1054

120VAC CONTROL
to 418
1053

NEUTRAL
to 418
1054

- NOTES:
1. ALL WIRES TO BE xxxV, xx*, xxx.
 2. OBSERVE DIRTY/CLEAN WIRING PRACTICES.
 3. Dx/Cx MARKERS INDICATE WIRE WAY ROUTING FOR THE SELECTED WIRES (Dx = DIRTY, Cx = CLEAN)
 4. ALL WIRES ARE #xx AWG, UNLESS OTHERWISE NOTED.
 5. ALL WIRES ARE xxx, UNLESS OTHERWISE NOTED.
 6. ALL GROUND WIRES ARE #xx AWG xxxxxx, UNLESS OTHERWISE NOTED.

XXXXX_XXXX XXXXXX	CONNECTED COMPONENTS		DWG NO	DATE
	SINGLE DIR L-TYPE MUTING		EXAMPLE	05-22-09
120VAC CONTROL		DWG REV	A	
		SHEET	4	OF XX

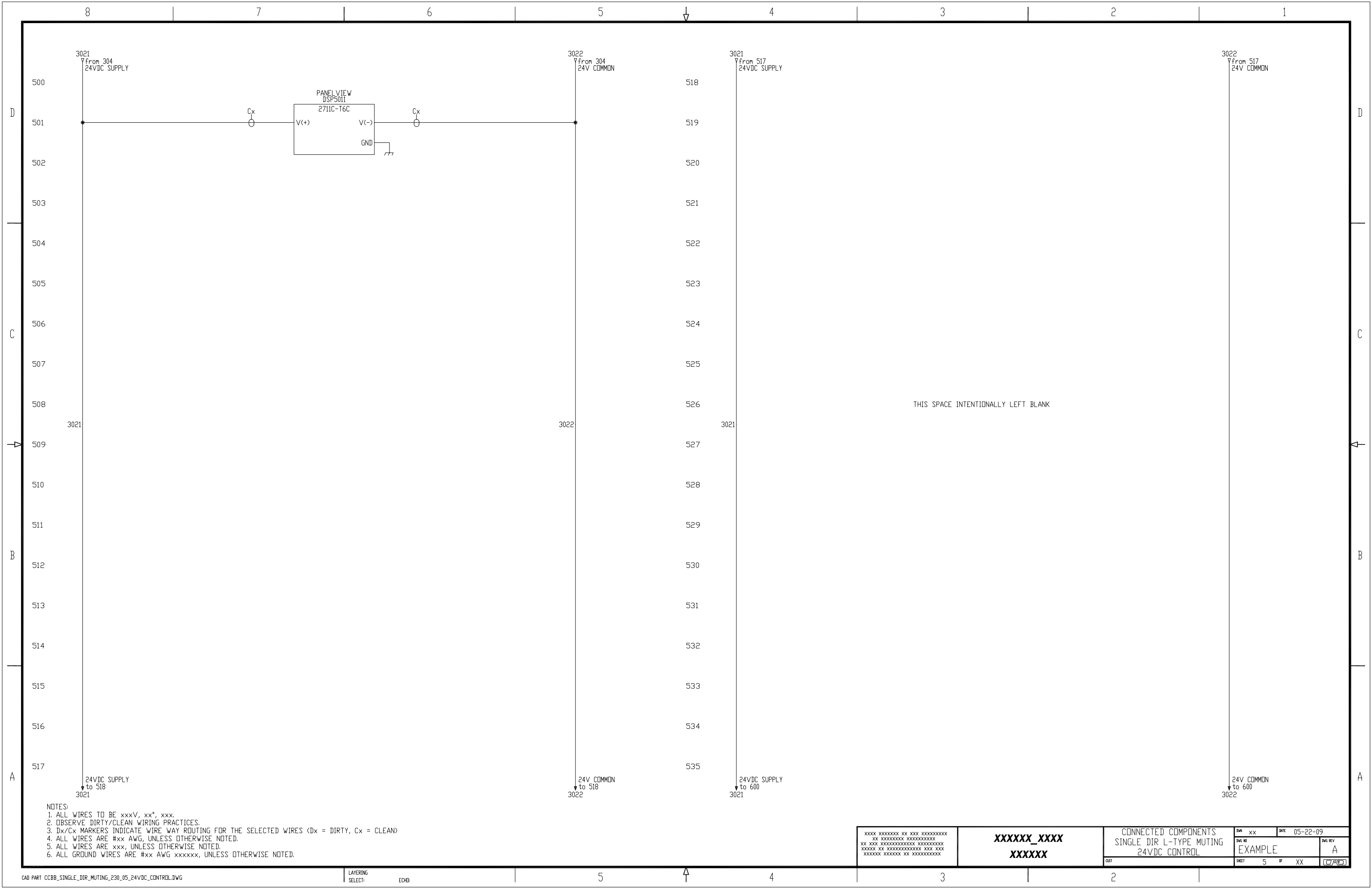

- NOTES:
1. ALL WIRES TO BE xxxV, xx*, xxx.
 2. OBSERVE DIRTY/CLEAN WIRING PRACTICES.
 3. Dx/Cx MARKERS INDICATE WIRE WAY ROUTING FOR THE SELECTED WIRES (Dx = DIRTY, Cx = CLEAN)
 4. ALL WIRES ARE #xx AWG, UNLESS OTHERWISE NOTED.
 5. ALL WIRES ARE xxx, UNLESS OTHERWISE NOTED.
 6. ALL GROUND WIRES ARE #xx AWG xxxxxx, UNLESS OTHERWISE NOTED.

XXXXX_XXXX XXXXXX	CONNECTED COMPONENTS SINGLE DIR L-TYPE MUTING 24VDC CONTROL	DWG NO EXAMPLE	DATE 05-22-09
	DWT 5	DWG REV A	OF XX

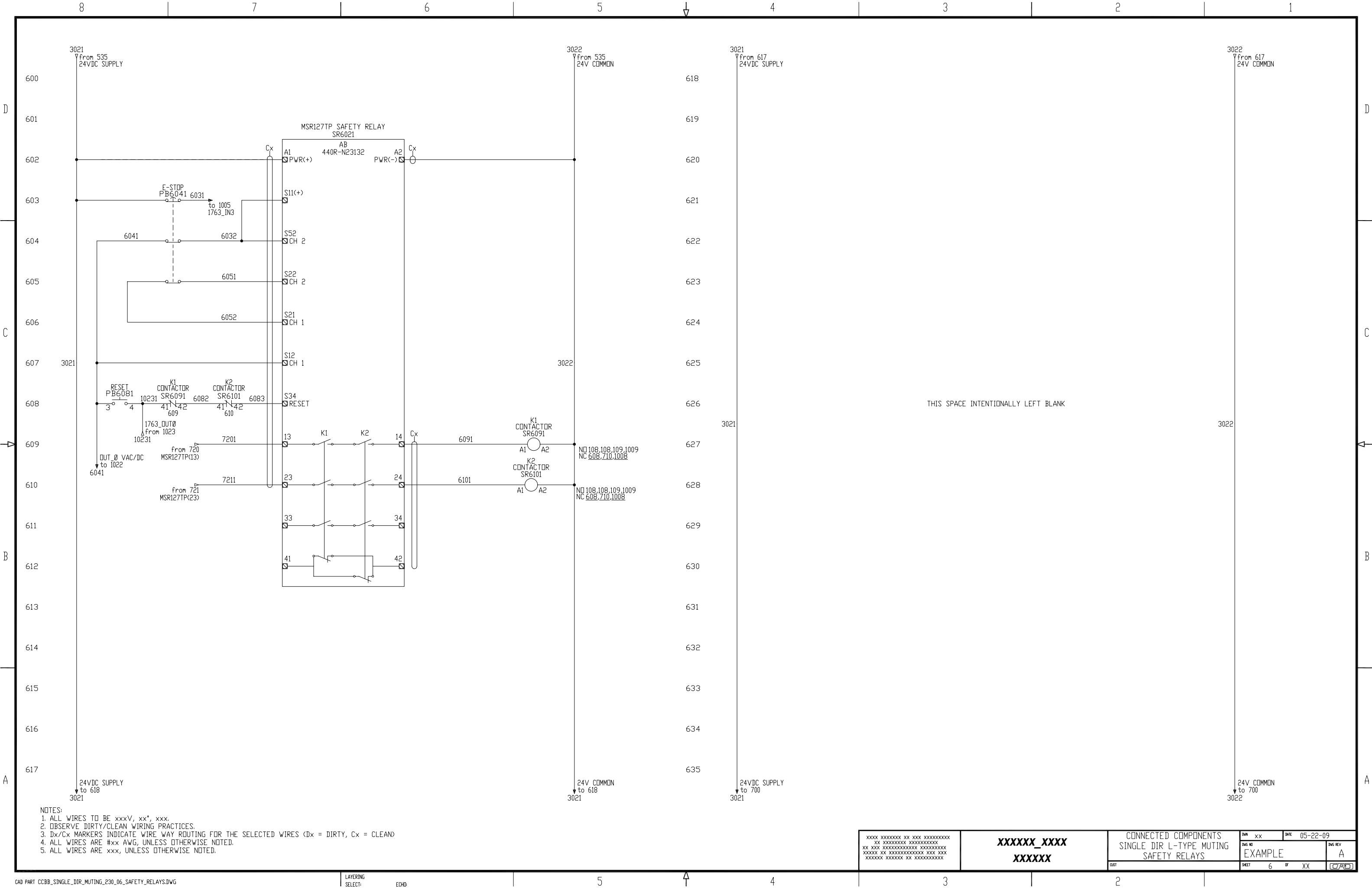

THIS SPACE INTENTIONALLY LEFT BLANK

- NOTES:
1. ALL WIRES TO BE xxxV, xx*, xxx.
 2. OBSERVE DIRTY/CLEAN WIRING PRACTICES.
 3. Dx/Cx MARKERS INDICATE WIRE WAY ROUTING FOR THE SELECTED WIRES (Dx = DIRTY, Cx = CLEAN)
 4. ALL WIRES ARE #xx AWG, UNLESS OTHERWISE NOTED.
 5. ALL WIRES ARE xxx, UNLESS OTHERWISE NOTED.

XXXX XXXXXXXX XX XXX XXXXXXXXXXXX XX XXXXXXXXXXXX XXXXXXXXXXXX XX XX XXXXXXXXXXXX XXXXXXXXXXXX XXXXX XX XXXXXXXXXXXX XXX XXX XXXXXX XXXXXX XX XXXXXXXXXXXX	XXXXXX_XXXX XXXXXX	CONNECTED COMPONENTS SINGLE DIR L-TYPE MUTING SAFETY RELAYS		DWG XX DATE 05-22-09
		DWT SHEET 6 OF XX	DWG REV EXAMPLE A	(C)

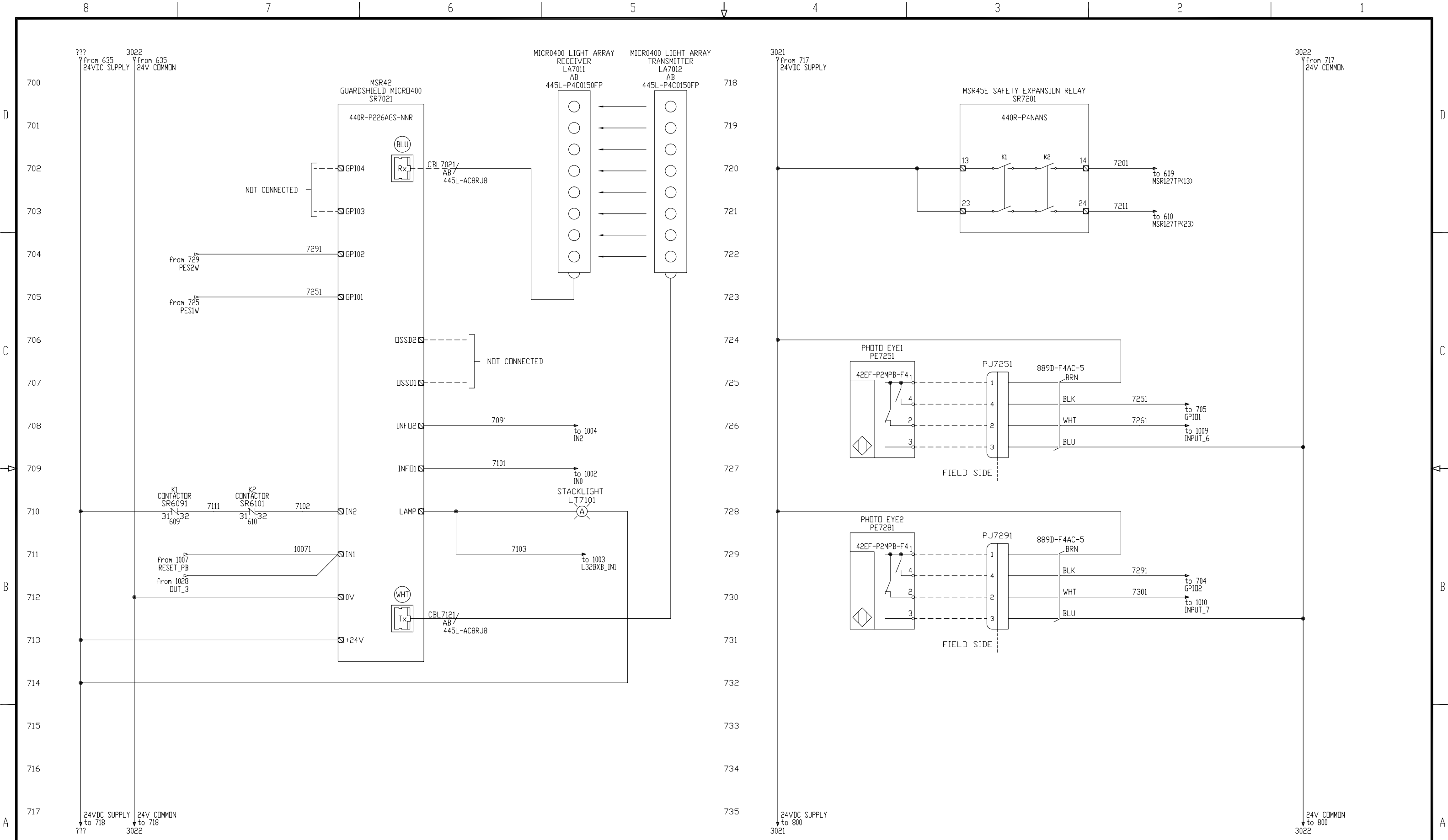

- NOTES:
1. ALL WIRES TO BE xxxV, xx*, xxx.
 2. OBSERVE DIRTY/CLEAN WIRING PRACTICES.
 3. Dx/Cx MARKERS INDICATE WIRE WAY ROUTING FOR THE SELECTED WIRES (Dx = DIRTY, Cx = CLEAN)
 4. ALL WIRES ARE #xx AWG, UNLESS OTHERWISE NOTED.
 5. ALL WIRES ARE xxx, UNLESS OTHERWISE NOTED.

XXXX XXXXXXXX XX XXX XXXXXXXXXXXX XX XXXXXXXXXXXX XXXXXXXXXXXX XXXXX XX XXXXXXXXXXXXXXXX XXX XXX XXXXXXX XXXXXXX XX XXXXXXXXXXXX	XXXXXX_XXXX XXXXXX	CONNECTED COMPONENTS SINGLE DIR L-TYPE MUTING SAFETY RELAYS	DWG NO EXAMPLE	DWG REV A
DWT 7	DATE 05-22-09	OF XX	(C)	

8

7

6

5

4

3

2

1

3021
from 735
24VDC SUPPLY

3022
from 735
24V COMMON

3021
from 817
24VDC SUPPLY

3022
from 817
24V COMMON

800
801
802
803
804
805
806
807
808
809
810
811
812
813
814
815
816
817

818
819
820
821
822
823
824
825
826
827
828
829
830
831
832
833
834
835

800
801
802
803
804
805
806
807
808
809
810
811
812
813
814
815
816
817

THIS SPACE INTENTIONALLY LEFT BLANK

THIS SPACE INTENTIONALLY LEFT BLANK

3021

3022

3021

3022

24VDC SUPPLY
to 818
3021

24V COMMON
to 818
3022

24VDC SUPPLY
to 900
3021

24V COMMON
to 900
3022

XXXX XXXXXX XX XXX XXXXXXXX
XX XXXXXXXX XXXXXXXXXX
XX XXX XXXXXXXXXX XXXXXXXX
XXXXX XX XXXXXXXXXX XXX XXX
XXXXXX XXXXXX XX XXXXXXXXXX

XXXXXX_XXXX
XXXXXX

CONNECTED COMPONENTS
SINGLE DIR L-TYPE MUTING
DRIVES I/O

DWG NO
EXAMPLE

DWG REV
A

DATE 05-22-09
SHEET 8 OF XX

8

7

6

5

4

3

2

1

3021
from 835
24VDC SUPPLY

3022
from 835
24V COMMON

3021
from 917
24VDC SUPPLY

3022
from 917
24V COMMON

900
901
902
903
904
905
906
907
908
909
910
911
912
913
914
915
916
917

918
919
920
921
922
923
924
925
926
927
928
929
930
931
932
933
934
935

918
919
920
921
922
923
924
925
926
927
928
929
930
931
932
933
934
935

THIS SPACE INTENTIONALLY LEFT BLANK

THIS SPACE INTENTIONALLY LEFT BLANK

3021

3022

3021

3022

24VDC SUPPLY
to 918
3021

24V COMMON
to 918
3022

24VDC SUPPLY
to 1000
3021

24V COMMON
to 1000
3022

XXXX XXXXXX XX XXX XXXXXXXXXXXX XX XXXXXXXXXXXX XXXXXXXXXXXX XX XXX XXXXXXXXXXXX XXXXXXXXXXXX XXXXXX XX XXXXXXXXXXXX XXX XXX XXXXXX XXXXXX XX XXXXXXXXXXXX	XXXXXX_XXXX XXXXXX	CONNECTED COMPONENTS SINGLE DIR L-TYPE MUTING SPARE		DWG XX	DATE 05-22-09
		DWG NO EXAMPLE	DWG REV A	SHEET 9 OF XX	

5

4

3

2

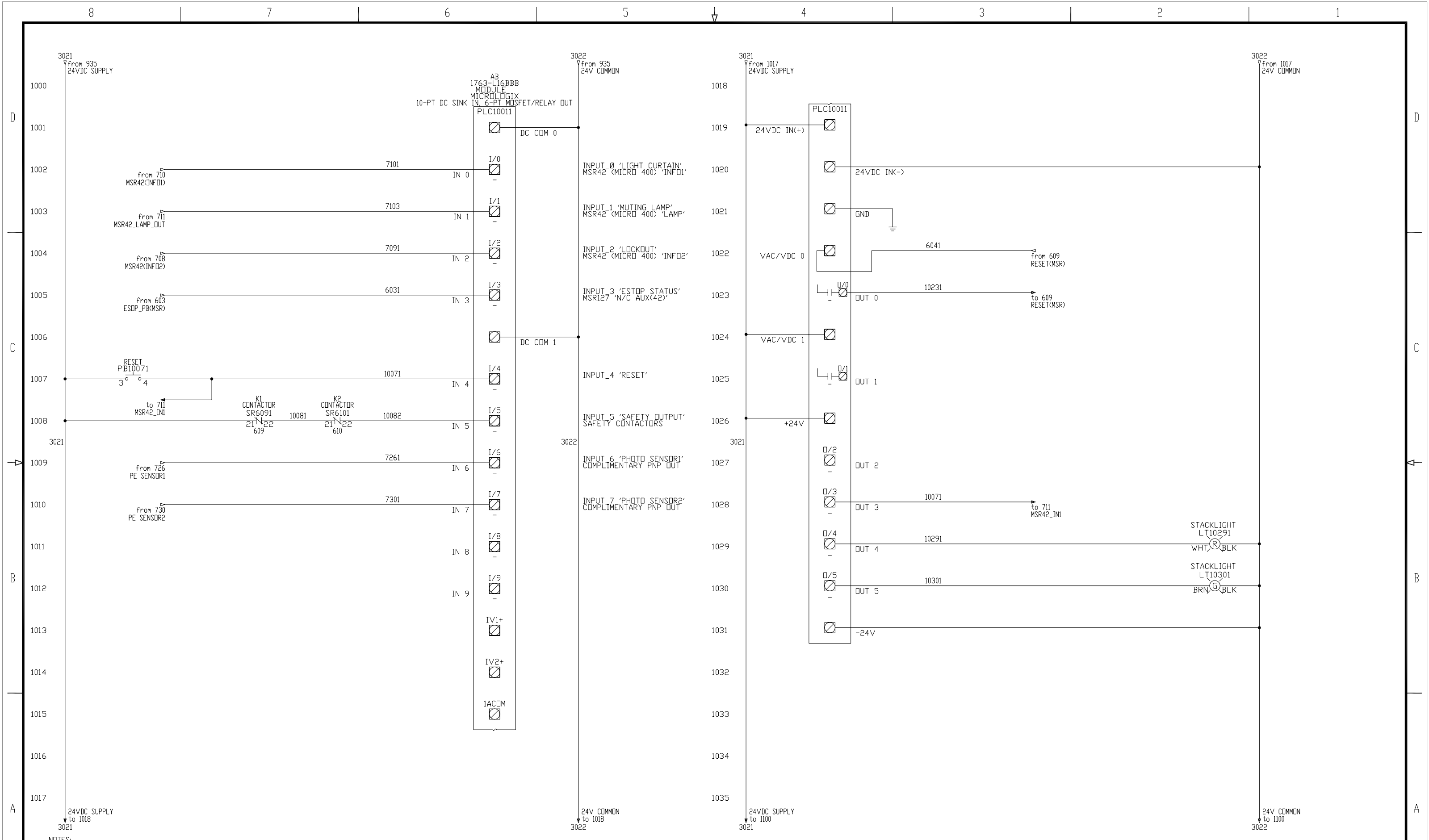

NOTES:
 1. ALL WIRES TO BE xxxV, xx*, xxx.
 2. OBSERVE DIRTY/CLEAN WIRING PRACTICES.
 3. Dx/Cx MARKERS INDICATE WIRE WAY ROUTING FOR THE SELECTED WIRES (Dx = DIRTY, Cx = CLEAN)
 4. ALL WIRES ARE #xx AWG, UNLESS OTHERWISE NOTED.
 5. ALL WIRES ARE xxx, UNLESS OTHERWISE NOTED.
 6. ALL GROUND WIRES ARE #xx AWG xxxxxx, UNLESS OTHERWISE NOTED.

XXXX XXXXXXXX XX XXX XXXXXXXXXXXX XX XXXXXXXXXXXXXXXXXXXXXXXXXXXX XXXXXX XX XXXXXXXXXXXXXXXXXXXX XXXXXXXXXXXXXXXXXX XX XXXXXXXXXXXXXXX	XXXXXX_XXXX XXXXXX	CONNECTED COMPONENTS SINGLE DIR L-TYPE MUTING PLC I/O	DWG NO EXAMPLE	DATE 05-22-09	DWG REV A
			SHEET 10 OF XX		

8

7

6

5

4

3

2

1

3021
from 1035
24VDC SUPPLY

3022
from 1035
24V COMMON

3021
from 1117
24VDC SUPPLY

3022
from 1117
24V COMMON

1100
1101
1102
1103
1104
1105
1106
1107
1108
1109
1110
1111
1112
1113
1114
1115
1116
1117

1118
1119
1120
1121
1122
1123
1124
1125
1126
1127
1128
1129
1130
1131
1132
1133
1134
1135

THIS SPACE INTENTIONALLY LEFT BLANK

THIS SPACE INTENTIONALLY LEFT BLANK

3021

3022

3021

3022

24VDC SUPPLY
to 1118
3021

24V COMMON
to 1118
3022

XXXX XXXXXX XX XXX XXXXXXXXXXXX
XX XXXXXXXXXXXX XXXXXXXXXXXX
XX XXX XXXXXXXXXXXX XXXXXXXXXXXX
XXXXXXXX XX XXXXXXXXXXXX XXX XXX
XXXXXXXX XXXXXX XX XXXXXXXXXXXX

XXXXXX_XXXX
XXXXXX

CONNECTED COMPONENTS
SINGLE DIR L-TYPE MUTING
SPARE

DWG NO	DATE	DWG REV
EXAMPLE	05-22-09	A
SHEET	OF	
11	XX	

5

4

3

2

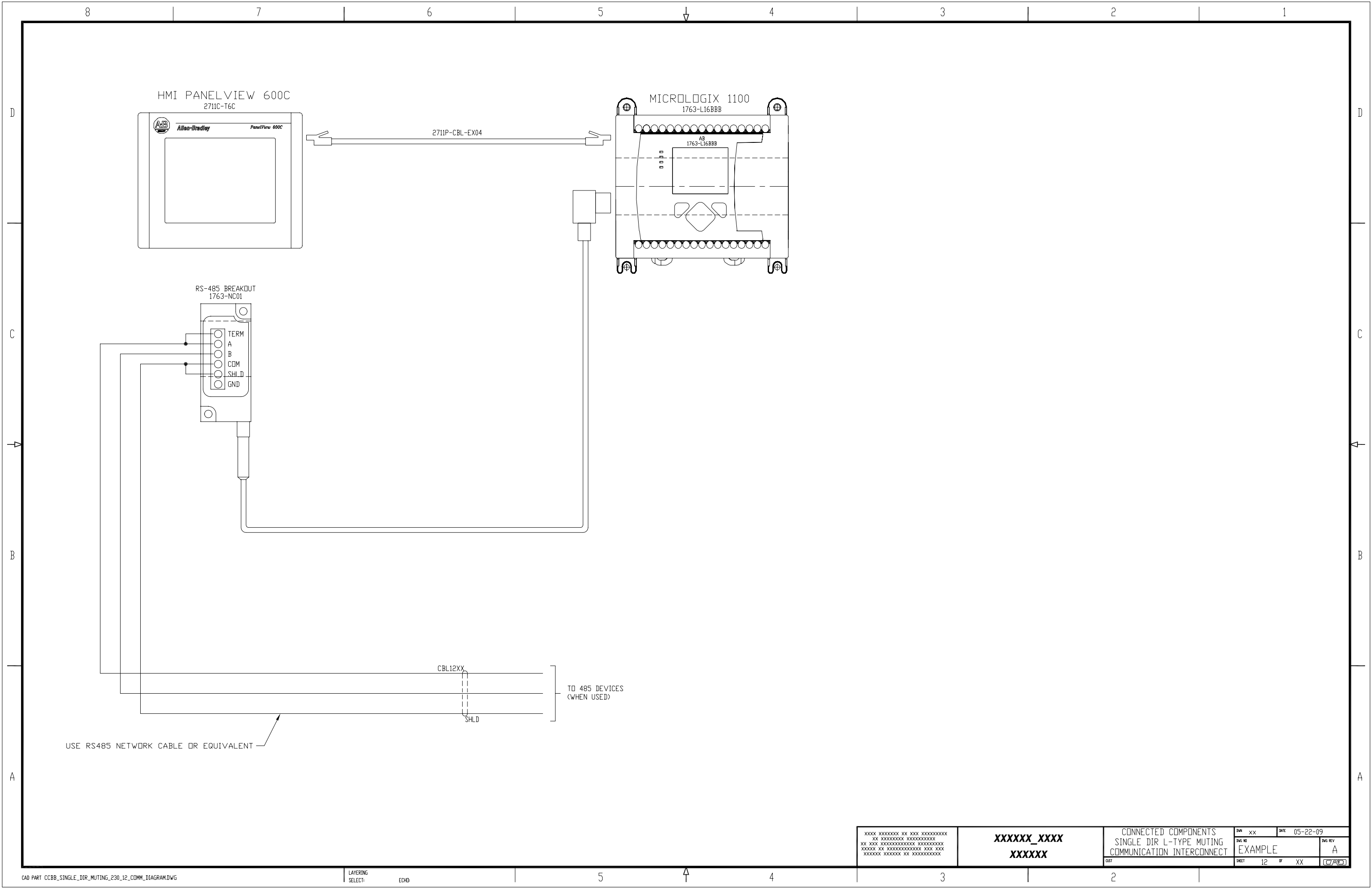

XXXX XXXXXXXX XX XXX XXXXXXXXXXXX XX XXXXXXXXXXXX XXXXXXXXXXXXXXXX XX XXX XXXXXXXXXXXXXXXXXXXXXXXXXXXX XXXXXX XX XXXXXXXXXXXXXXXXXXXX XXX XXX XXXXXXX XXXXXXX XX XXXXXXXXXXXXXXX	XXXXXX_XXXX XXXXXX	CONNECTED COMPONENTS SINGLE DIR L-TYPE MUTING COMMUNICATION INTERCONNECT	DWG XX DATE 05-22-09
		DWT SHEET 12 OF XX	DWT REV EXAMPLE A

8 7 6 5 4 3 2 1

D

C

B

A

D

C

B

A

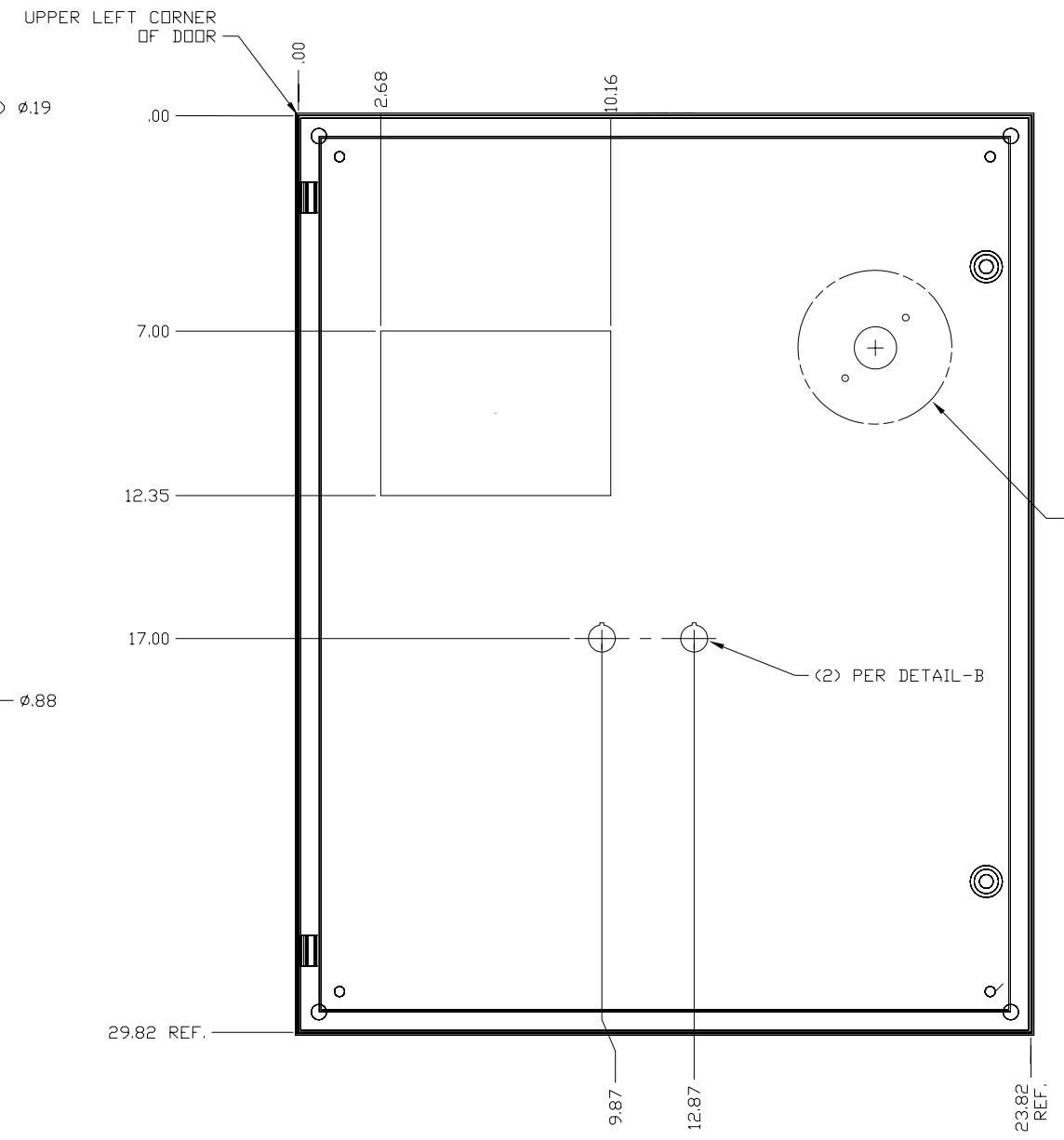
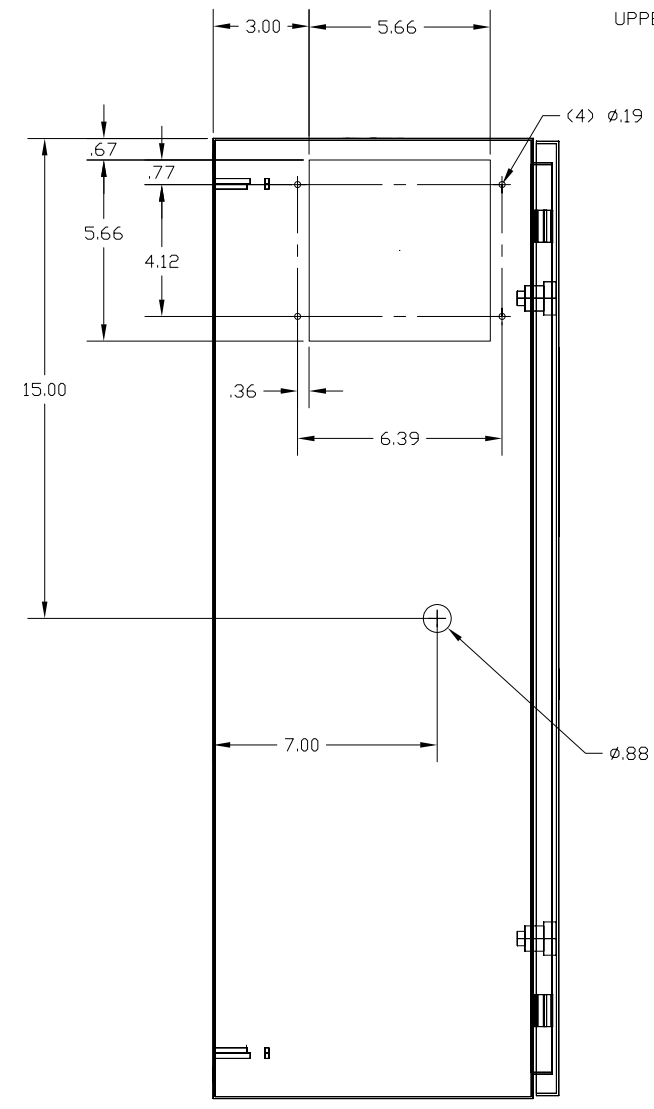
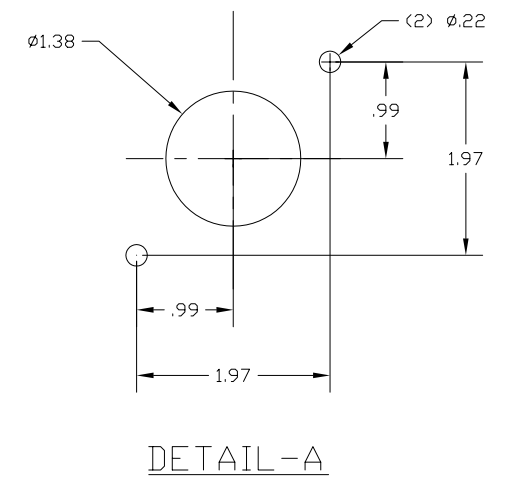
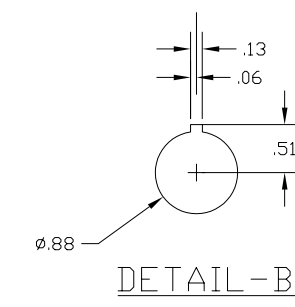
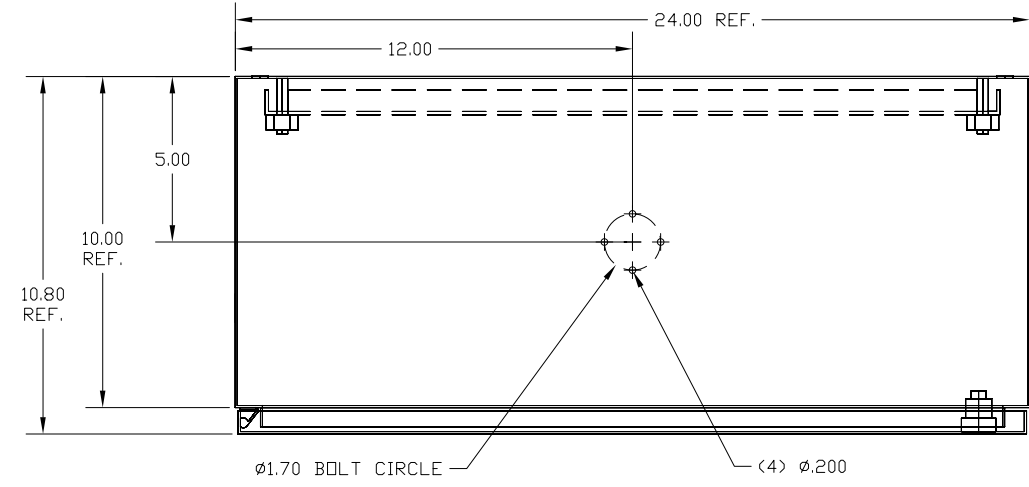

PER DETAIL-A,
(SEE SHEET 2 FOR ALL
OPERATOR OPTION
LOCATIONS)

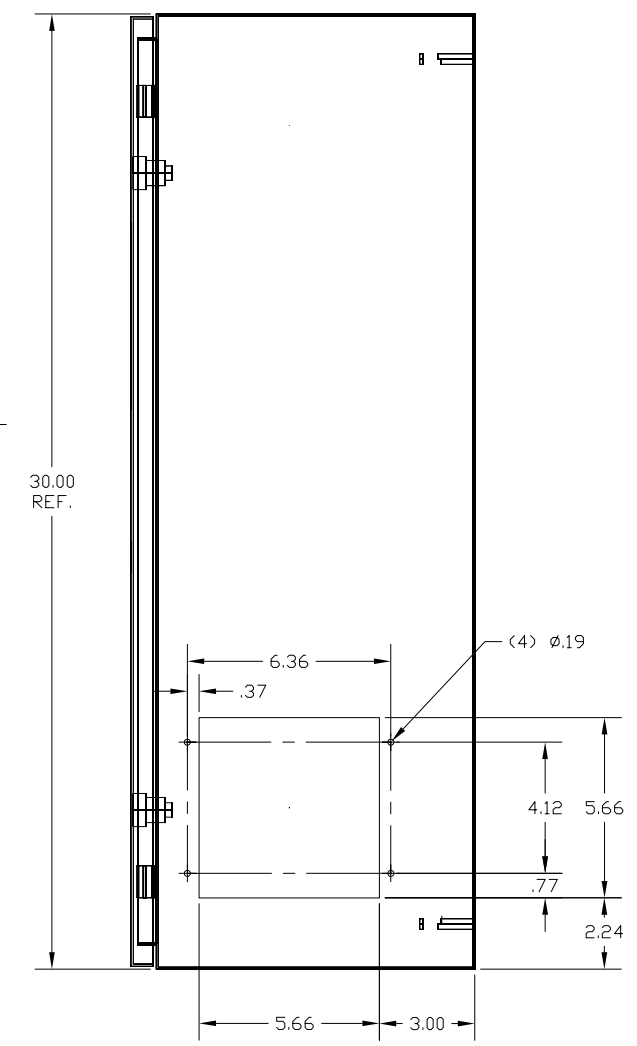

DOOR MODIFICATION

-01	1	HOFFMAN PART CSD302410	ANSI 61 GRAY
PART NO.	CHG. CHAR.	MATERIAL	SURFACE TREATMENT

LAYERING SELECT: ECHD

XXXX XXXXXXXX XX XXX XXXXXXXXXXXX XX XXXXXXXXXXXXXXXXXXXXXXXXXXXX XXXXXXXX XX XXXXXXXXXXXXXXXXXXXX XXXXXXXX XXXXXXX XXXXXXXXXXXXXXXX	XXXXXX_XXXX XXXXXX	CONNECTED COMPONENTS SINGLE DIR L-TYPE MUTING ENCLOSURE DOOR LAYOUT	DWG NO. XX DATE 05-22-09 EXAMPLE SHEET 14 OF XX	DWG REV XX CADD
---	-------------------------------------	---	--	--------------------

8 7 6 5 4 3 2 1

8

7

6

5

4

3

2

1

ADDITIONAL PARTS LIST

ITEM	DESCRIPTION	MFG	CATALOG
55	ROTARY VARIABLE DEPTH MECHANISM	AB	140U-RVM12R
56	"F" FRAME CIRCUIT BREAKER	AB	140UE-H2EA-C32
57	30A FUSED DISCONNECT	AB	194R-C30-1753
58	60A FUSED DISCONNECT	AB	194R-D32/D63-1753
59	MICROLOGIX 1400, 24VDC POWER	AB	1766-L32BXBA
60	STRATIX 6000, 8 PORT ETHERNET SWITCH	AB	9300-8EDM
61	REMOTE ACCESS ETHERNET SWITCH	AB	9300-RADES
62	STRATIX 6000 SWITCH, ENTRY-LEVEL MANAGED, 8-PORT	AB	1783-EMS08T
63	STRATIX 2000 SWITCH, UNMANAGED, 5-COPPER PORTS	AB	1783-US05T

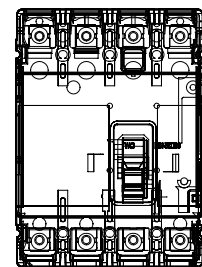

56 "F" FRAME CIRCUIT BREAKER

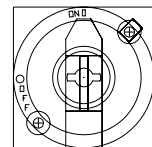

55 ROTARY VARIABLE DEPTH MECHANISM

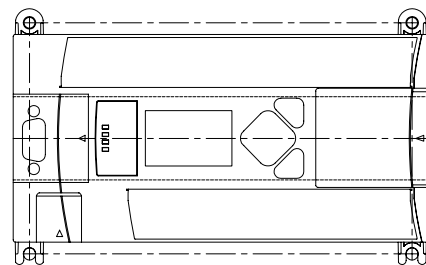

59 MICROLOGIX 1400

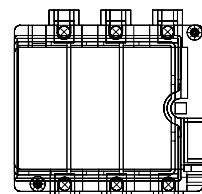

57 30A FUSED DISCONNECT

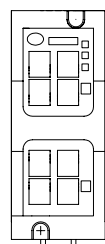

60 ETHERNET SWITCH

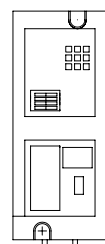

61 REMOTE ACCESS ETHERNET SWITCH

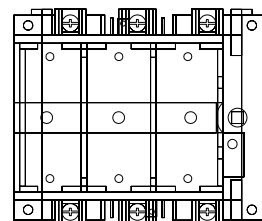

58 60A FUSED DISCONNECT

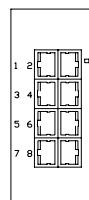

62 ETHERNET SWITCH

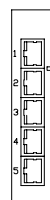

63 ETHERNET SWITCH

XXXX XXXXXXXX XX XXX XXXXXXXXXXXX
 XX XXXXXXXXXXXX XXXXXXXXXXXX
 XX XXX XXXXXXXXXXXX XXXXXXXXXXXX
 XXXXXX XX XXXXXXXXXXXX XXX XXX
 XXXXXXX XXXXXXX XX XXXXXXXXXXXX

XXXXXX_XXXX
 XXXXXXX

CONNECTED COMPONENTS
 SINGLE DIR L-TYPE MUTING
 ADDITIONAL PARTS

DWG NO	DATE	DWG REV
EXAMPLE	05-22-09	A
SHEET	OF	
15	XX	

5

4

3

2